

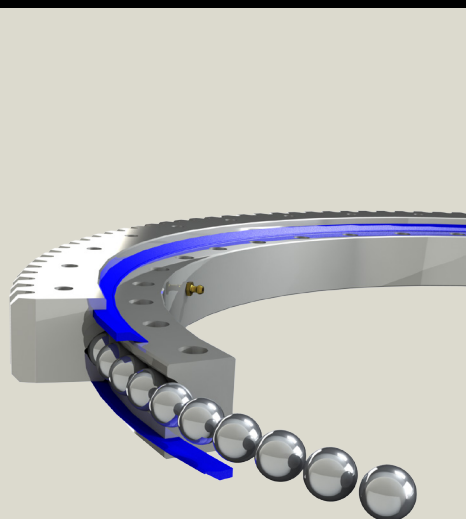

TGBGROUP
SLEWING RINGS

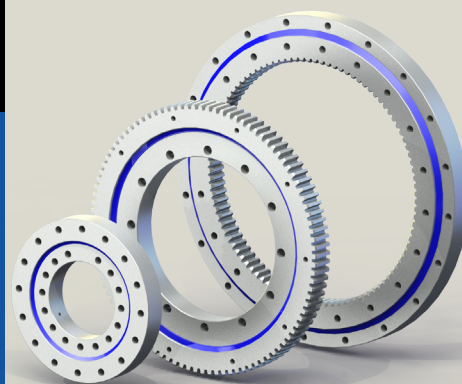

WWW.TGB-GROUP.COM

we *move*

Your movement solutions

TGB GROUP

With over 20 years of experience in bearings, gears and power transmission, the TGB Group has become a global leader in the development and production of movement solutions for the industrial and renewable energy markets. The TGB Group has manufacturing facilities on different continents which enables us to provide competitive solutions and customise projects while being able to retain a flexible manufacturing system and offer worldwide deliveries!

Our aim is to forge long lasting relationships with our customers by demonstrating our commitment throughout the engineering process, by exceeding customer expectations, by providing excellent service and by offering the best value for money.

Our knowledge and experience will enable you to make the right choice!

TGB Group S.L.



INDEX

APPLICATIONS	6
TECHNICAL INFORMATION	8
CALCULATION AND CHECK	9
INSTALLATION & MAINTENANCE	12
E SERIE	14
I SERIE	21
SD SERIE	28
U SERIE	32
Z SERIE	33
ACCESSORIES.....	34

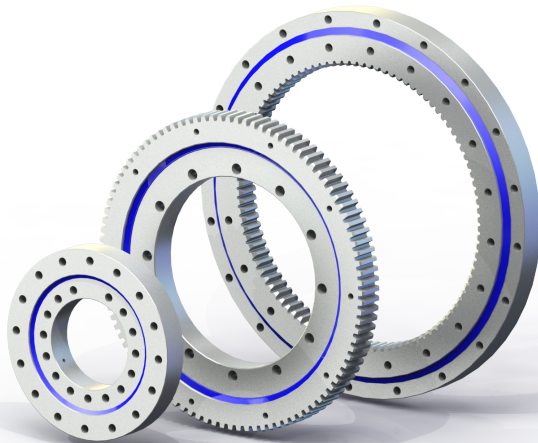

APPLICATION EXAMPLES



ROTARY TABLES



FORK LIFT



MOBILE CRANE

APPLICATION EXAMPLES



MAN LIFT



MACHINERY



CRANES

SLEWING RINGS TECHNICAL INFORMATION

INTRODUCTION

Slewing rings are mechanical elements designed to withstand high loads (axial, radial and tilting moment) while performing rotational movements to displace the load. The axial loads are the ones applied on the same direction as the rotation axis, while the radial loads are perpendicular to this axis.

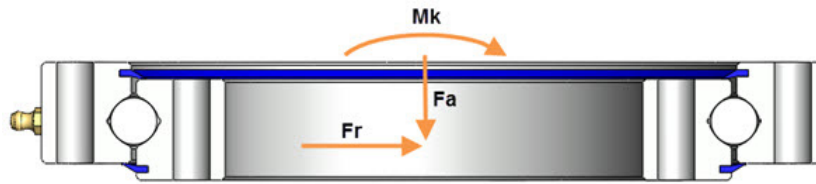

The main parts of the slewing ring are two rotating rings and the rolling elements between them. Both rings are provided with holes for bolts that can be threaded or through holes to fix the part to the structure. All the slewing rings without teeth can be also ordered with inner teeth or outer teeth.

The slewing ring load capability depends on its size and geometry and also on the type and amount of the rolling elements. For each slewing ring there is a load diagram that shows the maximum load that the slewing ring can withstand in terms of axial load and tilting moment.

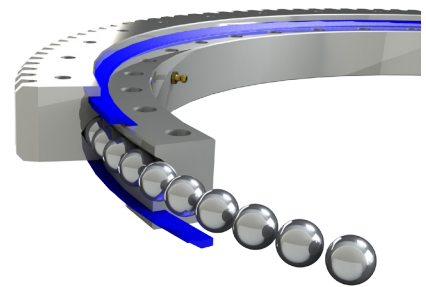

In order to choose the proper slewing ring for each application, please follow the procedure mentioned in the below flow chart:

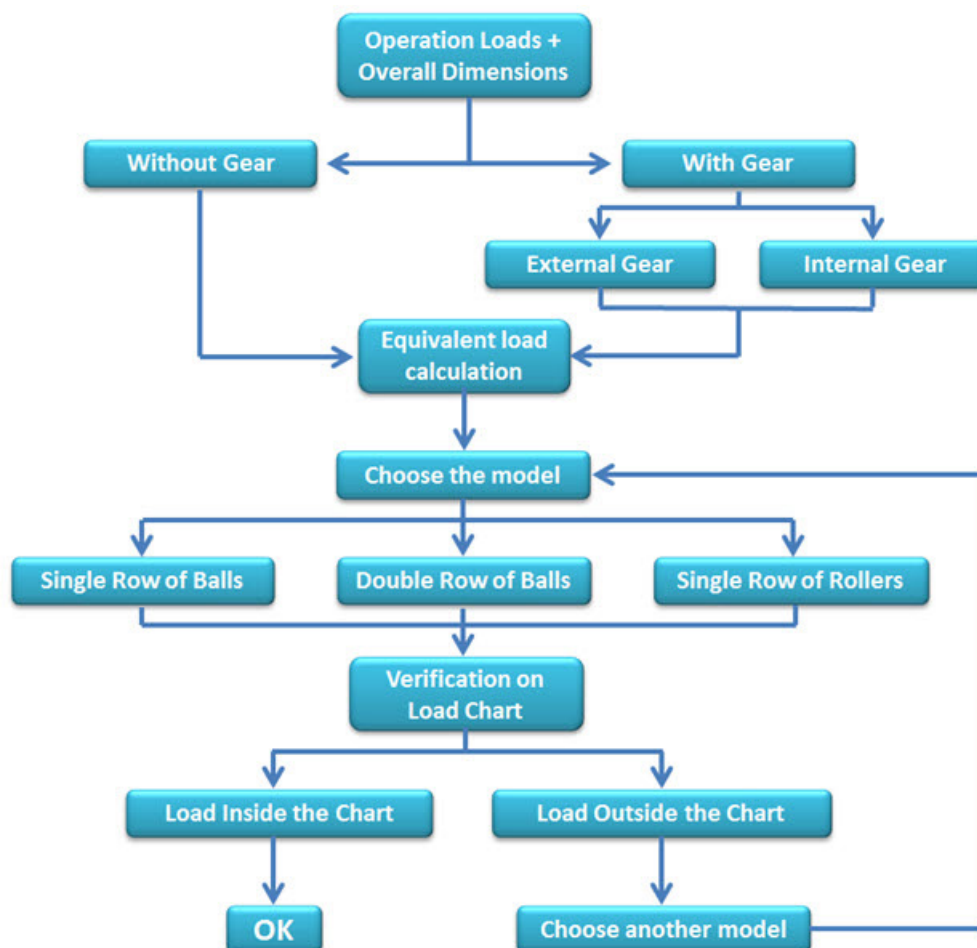

SLEWING RING CALCULATION AND CHECK

EQUIVALENT LOAD CALCULATION

First of all, the loads that the slewing ring will be supported have to be defined. To take into account the differences between an application of high-precision and another one that receives high mechanical stress, different application factors must be considered. These are shown in the table below for different load cases.

For application	Application criteria / requirements	Application service factor
Melting	Extreme operating	1,5
Construction machinery (e.g. cranes)	Extreme operating	1,25
Vehicles and installation on vehicles	Extreme operating	1,25
Forklift truck and grader	Light shocks	1,1
Water purification plants	Vibrations	1,25
Wind turbines	High shocks	2,0
Robots	Rigidity	1,25
Antennas	Precision	1,5
Machine-tooling	Precision	1,5
Measuring technology	Smooth running	2,0

Table 1: Application factor depending on application

TGBgroup recommends adding a safety factor to the loads, for greater caution, depending on the amount of working hours, the frequency at which the peak loads occur, etc. These factors will be applied in the axial load and tilting moment as follows:

$$F'_a = F_a \cdot f_A \cdot f_S$$

$$M'_k = M_k \cdot f_A \cdot f_S$$

If the slewing ring is subjected to radial loads, a radial static factor must be considered. This factor is calculated using the following procedure:

1. Calculate the ratio F_r/F_a
2. Calculate the load eccentricity characteristic using:
3. Obtain f_{0r} from the graphs shown below:

$$e = \frac{2000 \cdot M_k}{F_a \cdot D_L}$$

$F_r \rightarrow$ Radial load [KN]
 $M_k \rightarrow$ Tilting moment [KNm]
 $F_a \rightarrow$ Axial load [KN]
 $D_L \rightarrow$ Raceway diameter [mm]

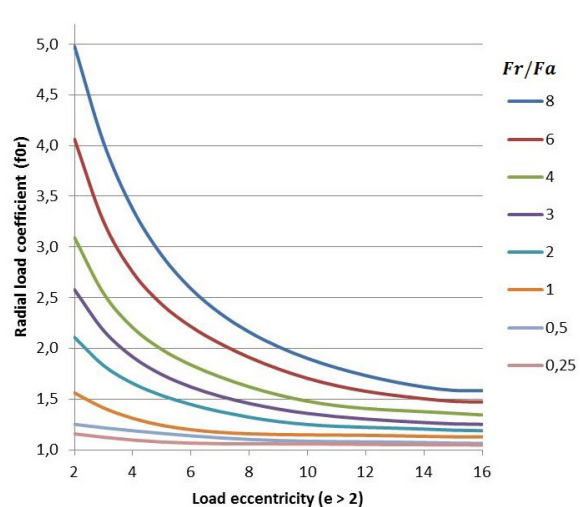
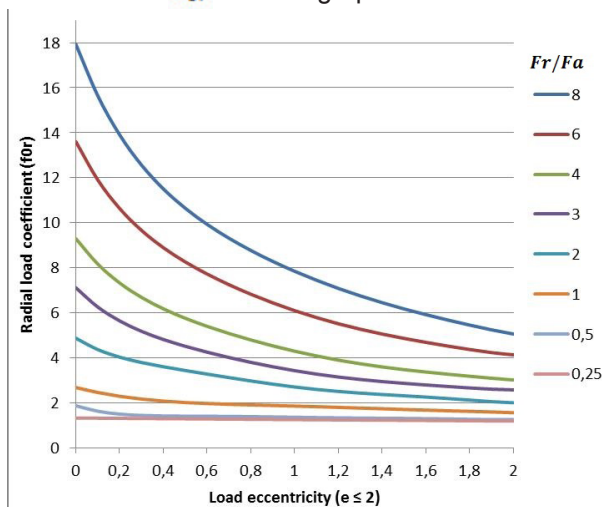

4. Apply this coefficient to the axial load and the tilting moment as follows:

$$F'_a = F_a \cdot f_A \cdot f_S \cdot f_{0r}$$

$$M'_k = M_k \cdot f_A \cdot f_S \cdot f_{0r}$$

Once the equivalent axial load and tilting moment have been obtained, it is possible to start choosing the slewing ring and check in the load chart whether it can withstand these loads or not.

SLEWING RING CALCULATION AND CHECK

RACEWAY

Each slewing ring has a corresponding load chart which shows the maximum axial load and tilting moment that it is able to withstand (The load chart safety factor is 1). A slewing ring is correct for the application if the loading point (combination between axial load and tilting moment) is below its load curve.

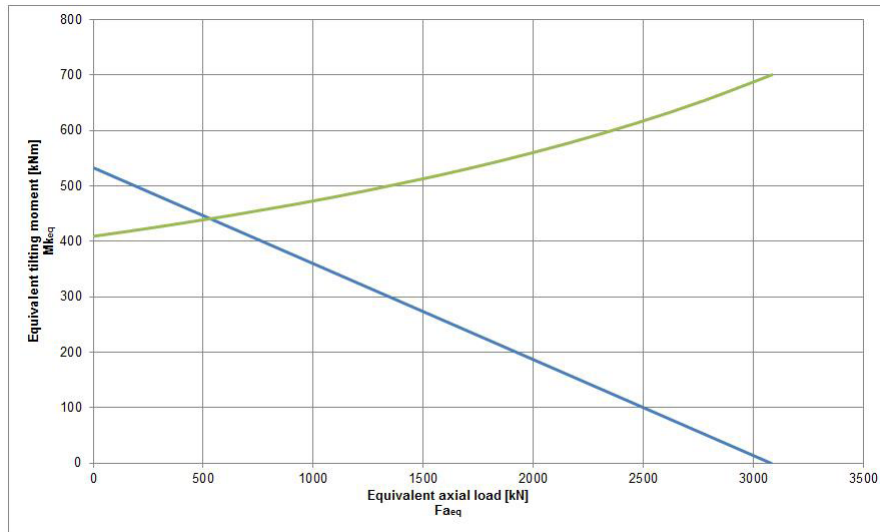

The vertical axis represents the equivalent tilting moment and the horizontal axis indicates the equivalent axial load. The blue line indicates the load limit of the slewing ring considering the raceway while the green line shows the load limit of the slewing ring screws. A slewing ring will be valid statically only if the point where intersect the equivalent axial force moment with equivalent tilting moment is below both lines.

In case the maximum load occurs frequently during rotation movement or a dynamic study of the slewing ring is required, please contact with TGBgroup technical department for assistance. Usually the life of the slewing ring is around 30000 load cycles. For highly demanding applications, vibration or shocks, it is recommended to contact the technical department for a detailed calculation adapted to the application.

SCREWS

There are some requirements regarding the screws that must be fulfilled to ensure that the limit bolt curve on the load charts is valid:

- All the holes of the slewing ring must be used when assembling it to the structure.
- All the holes must be tightened to the appropriate tightening torque (Table 2).
- The limit bolt curve is only valid when the bolts are working under compression loads.
- The bolt quality must be 10.9.
- The threaded length of the bolt must be at least 1.5 times the bolt diameter except when using nuts.
- As a general rule, it is always considered an additional flange of 20mm thickness.
- It is recommended a bolt length of 5 times the bolt diameter.

For pure radial loads we recommend contacting with the TGBgroup technical department to perform a more accurate study of the bolted union. In case the customer needs to ensure the union, for example for high vibration applications, we recommend the use of self-locking Nord-Lock washers or Loctite.

SLEWING RING CALCULATION AND CHECK

FRICTION TORQUE

All the slewing rings need a minimum torque to turn the slewing ring that depends on the loads applied, the lubrication, the preload on the slewing ring and the use or not of spacers. This value can be calculated using the following formulas:

Ball Slewing ring:

$$M_w = \frac{\mu}{2} (4.4 \cdot M_k + F_a \cdot D_L + 2.2 \cdot F_r \cdot D_L \cdot 1.73)$$

$M_w \rightarrow$ Torque resistance [KNm]

$D_L \rightarrow$ Raceway diameter [m]

$F_r \rightarrow$ Radial Load [KN]

$F_a \rightarrow$ Axial Load [KN]

$M_k \rightarrow$ Tilting moment [KNm]

$\mu \rightarrow$ Friction coefficient [KNm]

Roller Slewing ring:

$$M_w = \frac{\mu}{2} (4.1 \cdot M_k + F_a \cdot D_L + 2.05 \cdot F_r \cdot D_L)$$

$$\mu = 0.008$$

TEETH

For the toothed slewing rings, the maximum turning torque of the slewing ring will be limited by the module, the tooth height and the pitch diameter. There is a possibility to harden the teeth with a heat treatment to increase the maximum loads of the tooth a 20%.

On the slewing ring tables two values of load on the teeth appear: the first one corresponds to the fatigue limit while the second one corresponds to the breaking limit. When a turning torque is given, the force that the tooth shall withstand can be calculated with the next formula:

$$F_z = \frac{T \cdot 2000}{m \cdot z}$$

$F_z \rightarrow$ Tooth force [KN]

$T \rightarrow$ Torque [KNm]

$m \rightarrow$ Module

$z \rightarrow$ N° of teeth

For the choice of the pinion that will match the slewing ring, it must be taken into account that the pinion teeth must be higher than the slewing ring teeth (minimum difference = tooth module).

During installation of both parts, the clearance between flanks must be checked. This value has to be measured on the most eccentric part of the slewing ring and it must not exceed $0,04 \cdot m$ (where m refers to the module).

SLEWING RING SPEED

The maximum linear speed at which the slewing ring can work is 2m/s at the raceway. For slewing rings on vertical position this speed is limited at 1m/s. The formula used to convert the linear speed in angular speed is the one following:

$$\omega = \frac{2 \cdot v}{D_L} \cdot \frac{60}{2\pi}$$

$\omega \rightarrow$ Angular speed [rpm]

$v \rightarrow$ Linear speed [m/s]

$D_L \rightarrow$ Raceway diameter [m]

WORKING TEMPERATURE

The temperature working range of a slewing is sent between -20°C and 70°C .

INSTALLATION & MAINTENANCE INSTRUCTIONS

TRANSPORT, HANDLING AND STORAGE

Transport only in horizontal position avoiding possible impacts. The slewing ring should be manipulated carefully and wearing working gloves all the time. The threaded holes can be used to fix bolts to handle the slewing ring in a safety way with a hoisting device. Store always in horizontal position and in closed rooms. Keep it away from getting wet. The corrosion protection has a shelf-life of approx. 3 months in closed packaging.

INSTALLATION

Previous to the installation, a cleaning of the slewing ring and the structure where is going to be mounted must be done. During the cleaning process avoid the cleaning product to come inside the slewing ring. It is not allowed the cleaning of the slewing ring with steam high pressure systems.

It should be checked that the slewing ring is fully supported by the structure. Install the slewing ring on the mounting surface placing the filling plug for the balls (soft zone) at 90° from the main load zone. The slewing ring must be mounted without any external loads. It is convenient to perform working tests in the structure before the loads are applied.

The bolts used must be from the dimension, quantity and quality indicated. The slewing ring lifespan and functionality might be affected in case of non-compliance of the points mentioned above. TGBgroup recommends retightening the bolts after the first 3 months of operation at the appropriate tightening torque (Table 2).

Mounting bolt Dimension	Tightening torque M_t in Nm Quality class 10.9
M6	15 ± 1
M8	37 ± 3
M10	72 ± 6
M12	126 ± 10
M16	312 ± 25
M20	609 ± 50

Table 2: Tightening torques for Metric mounting bolts (non-lubricated thread)

LUBRICATION

Slewing rings are supplied with slewing ring raceway pre-lubricated. It is recommended to grease it again prior to initial operation and re-lubricated accordingly, depending on working conditions. The procedure to regrease consists in injecting grease into all grease nipples one after the other while rotating the slewing ring until a bead of fresh grease appears in one seal. For the toothed slewing rings, the contact area between teeth must also be greased, for example with a brush.

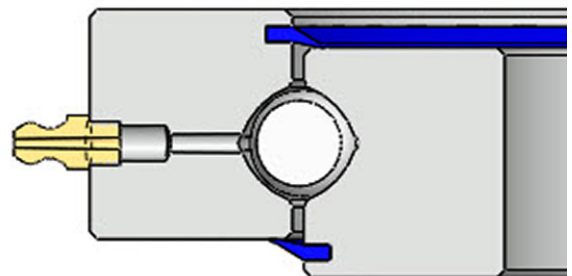

INSTALLATION & MAINTENANCE INSTRUCTIONS

The slewing rings must be re-greased after each cleaning and also before and after large periods of inactivity, for example during the winter months for cranes and building machines. The reason for re-lubrication is to guarantee minimum properties of the grease. On the following table the re-lubrication intervals can be seen for guidance.

The values on the table must never be a substitute for the values determined by the experience. The most usual cause for slewing ring failure is an insufficient amount of lubrication

Work conditions	Slewing drive Relubrication intervals
Dry and clean workshop, industrial positioners (turntables/robots, etc.)	every 300 hours of operation or once every 6 months
Difficult conditions in open grounds (crane/bulldozer, etc.) wind turbine solar, man lift	every 200 hours of operation or once every 6 months
Aggressive climatic conditions (sea/desert/Arctic climate/very dirty surrounding/more than 70 operating hours per week)	every 150 hours of operation or once every 4 months
Extreme conditions (tunnelling machines/steel mills)	every 50 operating hours, at least, however every 2 months

Table 3: Recommended re-lubrication intervals (only for guidance)

MAINTENANCE AND SECURITY CONTROLS

TGBgroup recommends retightening the bolts to the prescribed torque after no more than 100 working hours to compensate the possible settling. This should be done without external loads applied on the bolts union. This inspection should be repeated from then on every 3 months of work. The frequency of the inspection must be reduced under special working conditions.

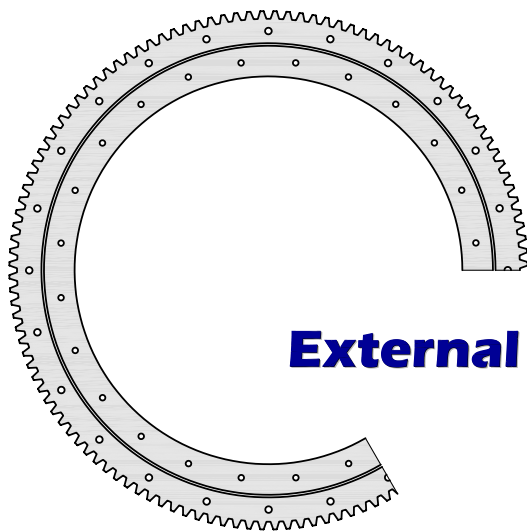

External gear

E.20.B

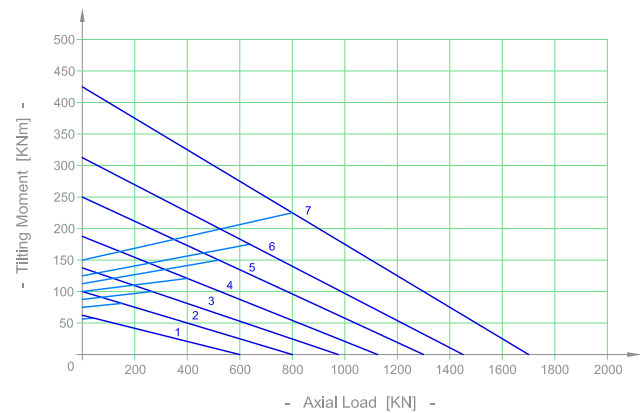
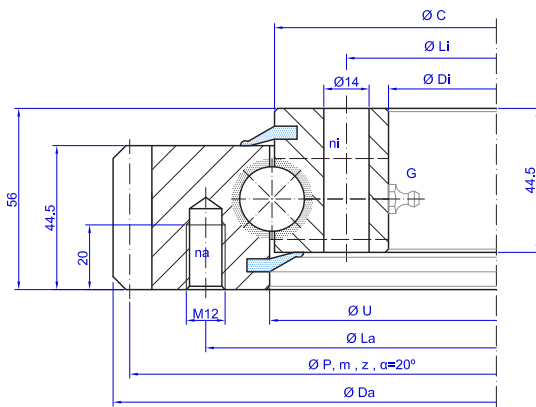

Bearing Type	Dimensions				Fixing holes				Gear teeth			Tooth Force		Mass
	Da mm	U mm	C mm	Di mm	La mm	na n°	Li mm	ni n°	P mm	m	z n°	Fz nor KN	Fz max KN	Weight KG
1 E.505.20.00.B	503,3	415,5	412,5	342	455	20	368	24	495	5	99	17,8	24,9	31
2 E.650.20.00.B	640,3	545,5	542,5	472	585	28	498	32	630	6	105	21,2	29,7	43
3 E.750.20.00.B	742,3	645,5	642,5	572	685	32	598	36	732	6	122	21,2	29,7	52
4 E.850.20.00.B	838,1	745,5	742,5	672	785	36	698	40	828	6	138	21,2	29,7	59
5 E.950.20.00.B	950,1	845,5	842,5	772	885	36	798	40	936	8	117	28,2	39,6	71
6 E.1050.20.00.B	1046,1	945,5	942,5	872	985	40	898	44	1032	8	129	28,2	39,6	77
7 E.1200.20.00.B	1198,1	1095,5	1092,5	1022	1135	44	1048	48	1184	8	148	28,2	39,6	91

G = N°4 x Grease nipples DIN 71412 AM 8x1 equally-spaced

Ask for a detailed drawing of the bearing, values may differ.

E.25.B

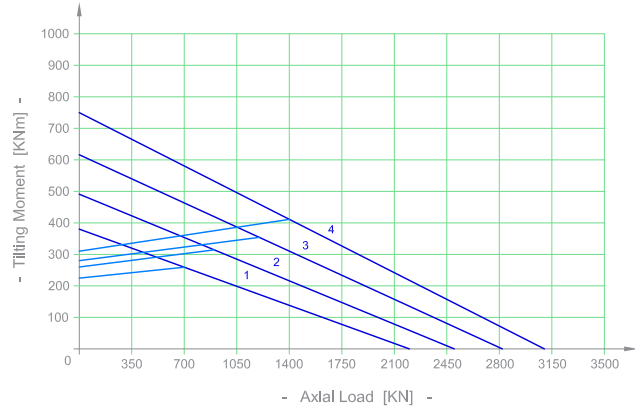
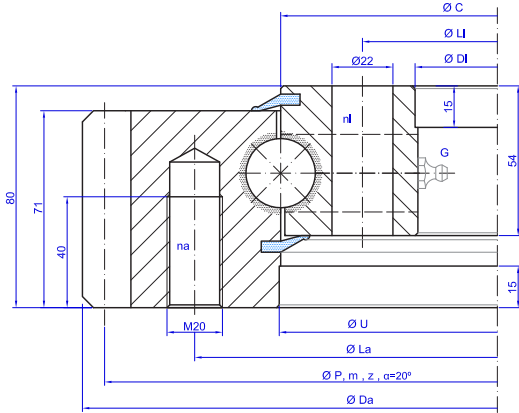

Bearing Type	Dimensions				Fixing holes				Gear teeth			Tooth Force		Mass
	Da mm	U +IT8 mm	C mm	Di +IT8 mm	La mm	na n°	Li mm	ni n°	P mm	m	z n°	Fz nor KN	Fz max KN	Weight KG
1 E.900.25.00.B	898	755	754	657	816	24	695	24	882	9	98	50,8	71,1	128
2 E.1000.25.00.B	997	855	854	757	916	28	795	28	981	9	109	50,8	71,1	145
3 E.1100.25.00.B	1096	955	954	857	1016	30	895	30	1080	9	120	50,8	71,1	155
4 E.1200.25.00.B	1198	1055	1054	957	1116	30	995	30	1180	10	118	55,5	77,6	171

G = N°4 x Grease nipples DIN 71412 AM 8x1 equally-spaced Ask for a detailed drawing of the bearing, values may differ.

E.20.C

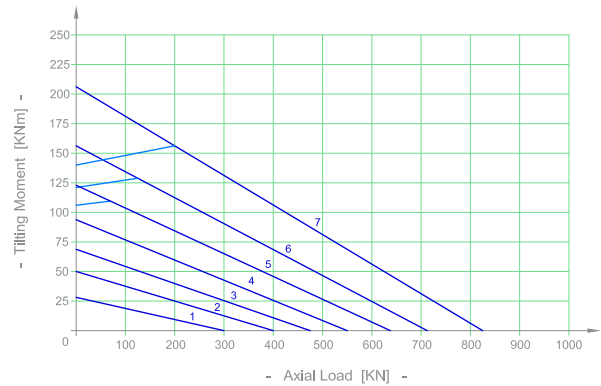
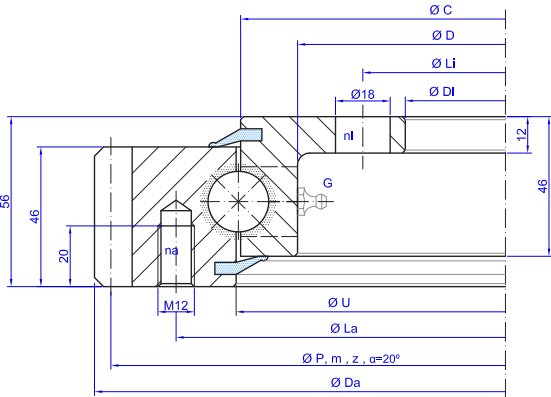

Bearing Type	Dimensions					Fixing holes				Gear teeth			Tooth Force		Mass
	Da mm	U mm	C mm	D mm	Di mm	La mm	na n°	Li mm	ni n°	P mm	m	z n°	Fz nor KN	Fz max KN	Weight KG
1 E.505.20.00.C	504	415,5	412,5	375	304	455	10	332	12	495	5	99	17,8	24,9	30
2 E.650.20.00.C	640,8	545,5	542,5	505	434	585	14	462	14	630	6	105	21,2	29,7	41
3 E.750.20.00.C	742,8	645,5	642,5	605	534	685	16	562	16	732	6	122	21,2	29,7	49
4 E.850.20.00.C	838,8	745,5	742,5	705	634	785	18	662	16	828	6	138	21,2	29,7	55
5 E.950.20.00.C	950,4	845,5	842,5	805	734	885	18	762	18	936	8	117	28,3	39,6	66
6 E.1050.20.00.C	1046,4	945,5	942,5	905	834	985	20	862	20	1032	8	129	28,3	39,6	71
7 E.1200.20.00.C	1198,4	1095,5	1092,5	1055	984	1135	22	1012	20	1184	8	148	28,3	39,6	83

G = N°4 x Grease nipples DIN 71412 AM 8x1 equally-spaced Ask for a detailed drawing of the bearing, values may differ.

E.32.C

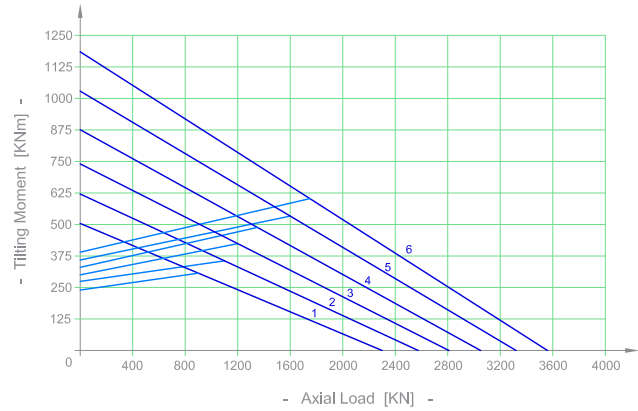
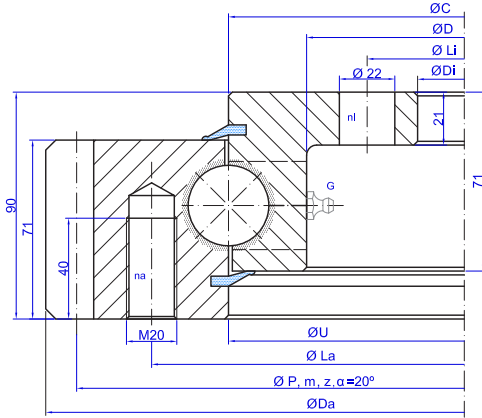

Bearing Type	Dimensions					Fixing holes				Gear teeth			Tooth Force		Mass
	Da mm	U mm	C mm	D mm	Di mm	La mm	na n°	Li mm	ni n°	P mm	m	z n°	Fz nor KN	Fz max KN	Weight KG
1 E.1100.32.00.C	1098	955	955	893	805	1016	30	845	30	1080	9	120	49,9	69,9	165
2 E.1200.32.00.C	1200	1055	1055	993	905	1116	30	945	30	1180	10	118	55,5	77,6	183
3 E.1300.32.00.C	1300	1155	1155	1093	1005	1216	36	1045	36	1280	10	128	55,5	77,6	200
4 E.1400.32.00.C	1400	1255	1255	1193	1105	1316	42	1145	42	1380	10	138	55,5	77,6	216
5 E.1500.32.00.C	1500	1355	1355	1293	1205	1416	42	1245	42	1480	10	148	55,5	77,6	234
6 E.1600.32.00.C	1600	1455	1455	1393	1305	1516	48	1345	48	1580	10	158	55,5	77,6	250

G = N°6 x Grease nipples DIN 71412 AM 10x1 equally-spaced Ask for a detailed drawing of the bearing, values may differ.

E.22.D

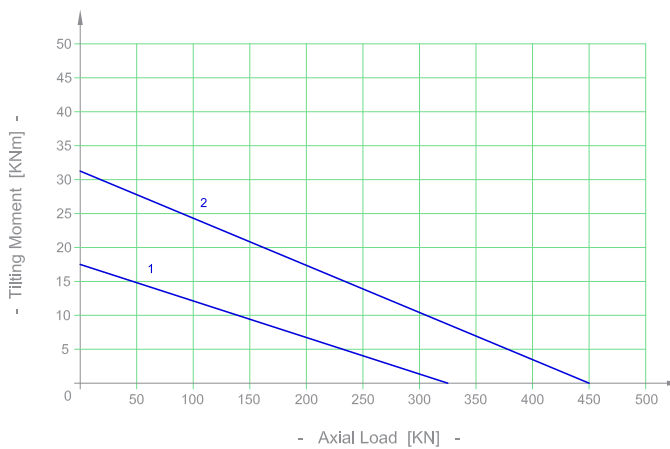
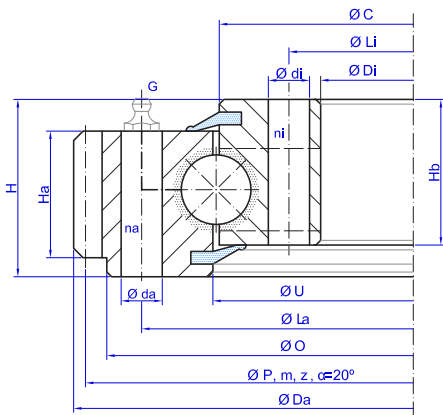

Bearing Type	Dimensions							Fixing holes					Gear teeth			Tooth Force		Mass	
	Da mm	O mm	U mm	D mm	Ha mm	Hb mm	H mm	La mm	na n°	da mm	Li mm	ni n°	di mm	P mm	m	z n°	Fz nor KN	Fz max KN	Weight KG
1 E.318.22.00.D.1	318	297	230	162	40	46	56	275	20	13	182	20-1	13	310,5	4,5	69	14,3	20	17
2 E.403.22.00.D.1	403,5	380	310	235	39	47	55	358	24	13	259	28-1	13	396	4,5	88	14,3	20	23

G = N°2 x Grease nipples DIN 71412 AM 10x1 equally-spaced Ask for a detailed drawing of the bearing, values may differ.

E.25.D

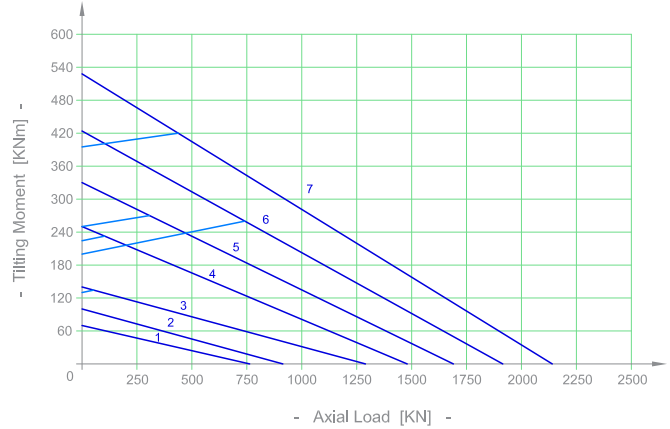
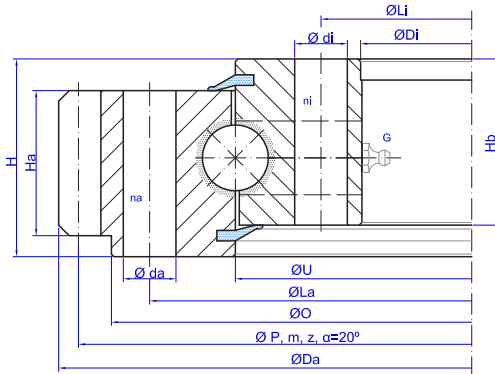

Bearing Type	Dimensions							Fixing					Gear teeth			Tooth Force		Mass	
	Da mm	O mm	U mm	Di mm	Ha mm	Hb mm	H mm	La mm	na n°	da mm	Li mm	ni n°	di mm	P mm	m	z n°	Fz nor KN	Fz max KN	Weight KG
1 E.535.25.00.D.1	535	495	401	306	55	63	75	466	18	20	336	18	20	520	8	65	34,2	47,9	65
2 E.589.25.15.D.1	589,5	565	475	384	40	63	75	540	36	16	410	36-1	16	580,5	4,5	129	14,9	21,4	60
3 E.595.25.00.D.6	595	565	477	382	50	55	65	540	18	17	410	18	17	585	5	117	19,5	27,3	58
4 E.864.25.00.D.5	864	835	771,5	680	57	65	82	800	24	M16	706	24	M16	852	6	142	26,9	37,7	85
5 E.972.25.00.D.3	972	942	854	766	58	60	70	912	36	M16	796	36	18	960	6	160	27,4	38,4	108
6 E.1080.25.00.D.5	1080	1042	987	895	62	64	82	1015	30	M16	922	30	M16	1064	8	133	40,4	56,5	120
7 E.1200.25.00.D1	1200	1163	1078	982	50	55	65	1135	30	18	1012	30	18	1184	8	148	31,5	44,1	140

G, G1 = For the number and the position of the grease nipples, please ask for a detailed drawing of the bearing

Ask for a detailed drawing of the bearing, values may differ.

E.32.D

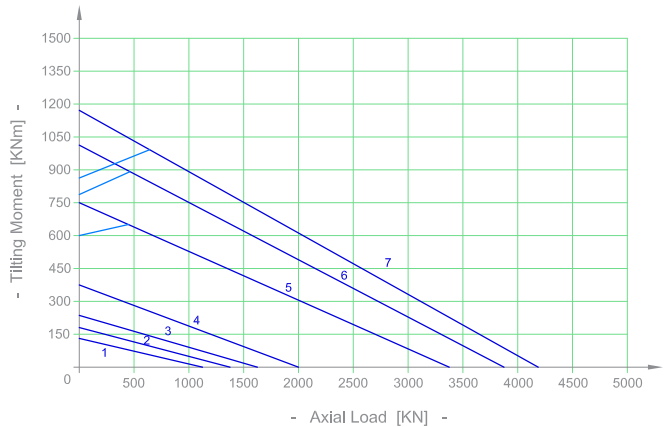
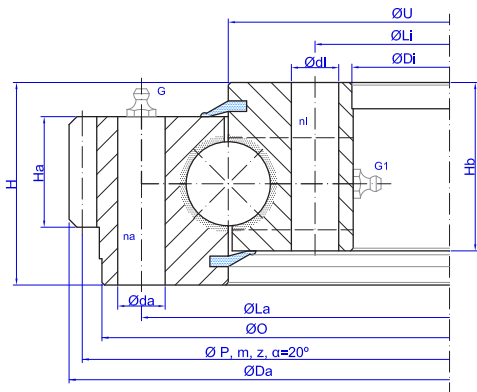

Bearing Type	Dimensions							Fixing holes					Gear teeth			Tooth Force		Mass	
	Da mm	O mm	U mm	Di mm	Ha mm	Hb mm	H mm	La mm	na n°	da mm	Li mm	ni n°	di mm	P mm	m	z n°	Fz nor KN	Fz max KN	Weight KG
1 E.595.32.00.D.1	595	565	475	382	65	75	88	540	24	18	410	24-1	18	585	5	117	25,4	35,5	80
2 E.695.32.15.D.1	695	670	574	480	42	64	77	640	36	18	508	36-1	18	685	5	137	18,3	26,1	77
3 E.816.32.00.D.1	816	781	682	574	65	70	90	753	18	22	604	18	22	792	6	132	29,4	41,2	122
4 E.980.32.00.D.1	979	932	845	718	65	82	100	893	36	22	753	36-1	22	940	10	94	52,1	72,9	167
5 E.1144.32.15.D.1	1144	1090	993	870	67	84	100	1050	36	22	910	36-1	22	1110	10	111	60,9	87,2	230
6 E.1289.32.15.D.1	1289,5	1240	1116	985	78	94	114	1198	40	22	1035	40	22	1250	10	125	64,7	92,7	330
7 E.1380.32.15.D.1	1380	1330	1212	1100	80	94	114	1290	36	22	1135	36	22	1360	10	136	67,4	97,2	350

G, G1 = For the number and the position of the grease nipples, please ask for a detailed drawing of the bearing

Ask for a detailed drawing of the bearing, values may differ.

E.2.20-22-25.D

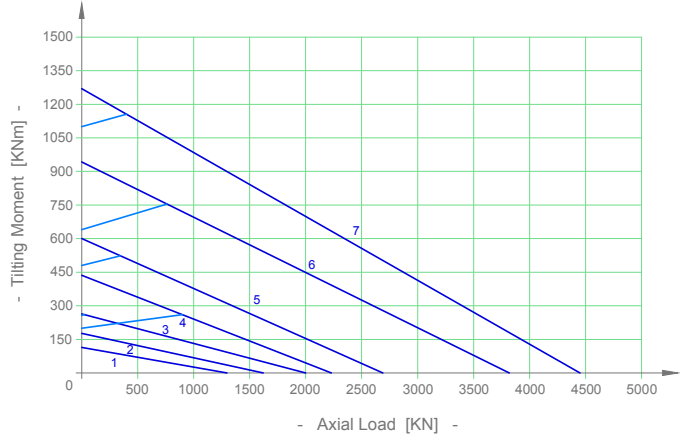
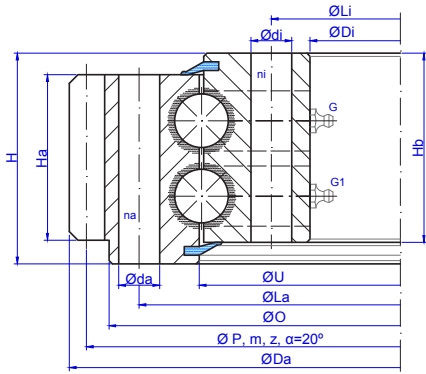

Bearing Type	Dimensions								Fixing holes					Gear teeth			Tooth Force		Mass
	Da mm	O mm	U mm	Di mm	Ha mm	Hb mm	H mm	La mm	na n°	da mm	Li mm	ni n°	di mm	P mm	m	z n°	Fz nor KN	Fz max KN	Weight KG
1 E.504.2.25.00.D.6	504	466	387	300	75	87	95	436	16	17	330	16	17	488	8	61	31	62	67
2 E.608.2.25.10.D.6	608	570	487	382	78	87	95	540	24	17	410	24	17	592	8	74	40	80	92
3 E.712.2.25.12.D.6	712	670	577	470	75	88	98	640	24	17	508	24	20	696	8	87	41	82	119
4 E.1079.2.20.12.D.3.V	1079	-	972	893	70	80	90	1015	30	M16	922	30	18	1048	8	131	42	84	140
5 E.1080.2.22.00.D.6	1080	1042	970	893	76	83	92	1015	30	17	992	30	17	1064	8	133	32	64	150
6 E.1200.2.25.00.D.1	1200	1163	1079	976	77	88	98	1135	36	19	1012	36	19	1184	8	148	32	64	210
7 E.1476.2.25.00.D.6	1476	1415	1250	1085	89	101	110	1350	48	26	1150	48	26	1440	10	144	77	154	503

G, G1 = For the number and the position of the grease nipples, please ask for a detailed drawing of the bearing Ask for a detailed drawing of the bearing, values may differ.

E.18-25.D-R

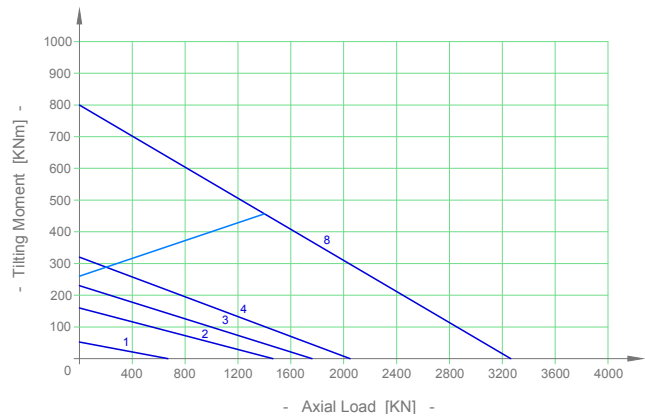
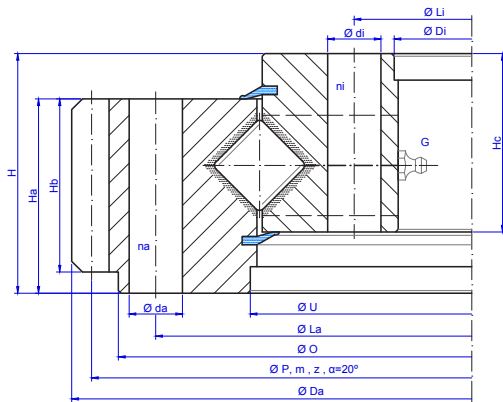

Bearing Type	Dimensions								Fixing holes					Gear teeth			Tooth Force		Mass	
	Da mm	O mm	U mm	Di mm	Ha mm	Hb mm	Hc mm	H mm	La mm	na n°	da mm	Li mm	ni n°	di mm	P mm	m	z n°	Fz nor KN	Fz max KN	Weight KG
1 E.403.18.15.D.1-RV	403,5	379	313	235	45	37	47	55	358	24	13	259	28-1	13	396	4,5	88	16,5	23,8	25
2 E.595.25.15.D.1-RV	595	565	480	382	70	60	70	85	540	24	17	410	24	17	585	5	117	10,4	20,8	76
3 E.695.25.15.D.1-RV	695	670	577	470	70	60	70	85	640	36	20	508	36-1	20	680	5	136	14,4	28,8	97
4 E.816.25.15.D.1-RV	816	781	682	574	73	65	70	90	753	18	22	604	18	22	792	6	132	40	57	118
5 E.1204.25.15.D.3-RV	1204	1158	1083,5	975	88	78	80	98	1130	36	M20	1012	36	21	1180	10	118	86	123	218

G = For the number and the position of the grease nipples, please ask for a detailed drawing of the bearing Ask for a detailed drawing of the bearing, values may differ.

E.30.D-R

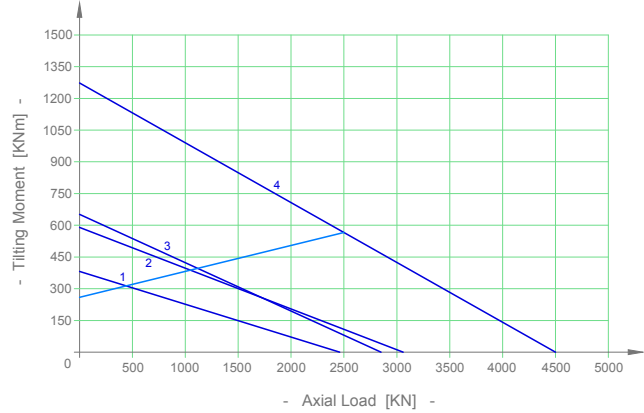
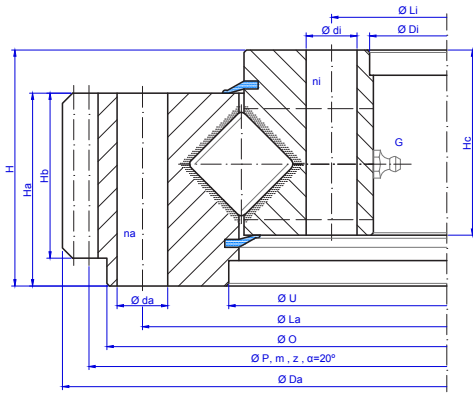

Bearing Type	Dimensions								Fixing holes					Gear teeth			Tooth Force		Mass	
	Da mm	O mm	U mm	Di mm	Ha mm	Hb mm	Hc mm	H mm	La mm	na n°	da mm	Li mm	ni n°	di mm	P mm	m	z n°	Fz nor KN	Fz max KN	Weight KG
1 E.816.30.15.D.1-RV	816	779	679	570	73	65	73	90	750	36	22	604	36-1	22	800	8	100	30,7	61,4	118
2 E.979.30.15.D.1-R	979	932	845	718	79	65	82	100	893	18	22	753	18	22	940	10	94	50	72	180
3 E.1144.30.12.D.1-RV	1144	1090	993	870	79	67	84	100	1050	36	22	910	36	22	1110	10	111	58	116	230
4 E.1390.30.15.D.1-R	1390	1320	1237	1115	93	89	85	105	1290	30	M20	1150	30	22	1368	12	114	82	164	329

G = For the number and the position of the grease nipples, please ask for a detailed drawing of the bearing Ask for a detailed drawing of the bearing, values may differ.

E.40-45.D-R

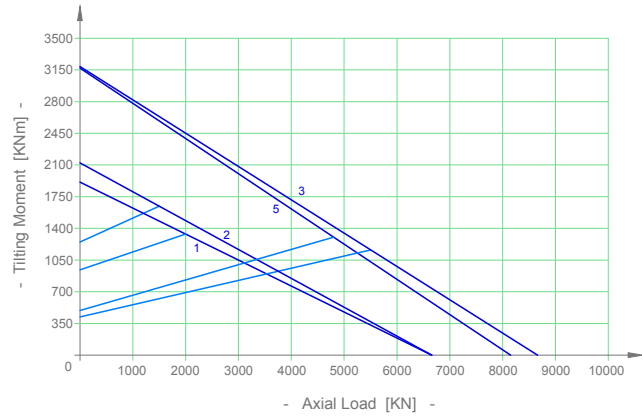
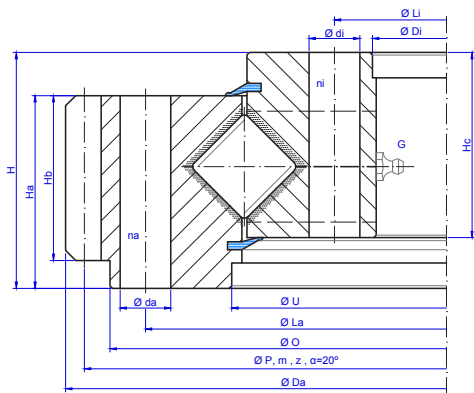

Bearing Type	Dimensions								Fixing holes					Gear teeth			Tooth Force		Mass	
	Da mm	O mm	U mm	Di mm	Ha mm	Hb mm	Hc mm	H mm	La mm	na n°	da mm	Li mm	ni n°	di mm	P mm	m	z n°	Fz nor KN	Fz max KN	Weight KG
1 E.1476.45.15.D.1-R	1476	1415	1252	1085	91	77	100	110	1350	25	26	1150	28	26	1440	10	144	64	93	484
2 E.1604.40.15.D.1-RV	1604	1551	1394	1208	112	85	116	130	1500	48	30	1280	48-1	30	1570	10	157	80	128	640
3 E.1805.45.17.D.3-R	1805	1730	1608	1437	125	120	115	140	1671	60	M27	1485	60	30	1744	16	109	167	250	720
4 E.1943.40.15.D.2-RV	1943	1877	1704	1529	90	89	90	100	1805	32	33	1595	32	M30	1904	14	136	110	180	691

G = For the number and the position of the grease nipples, please ask for a detailed drawing of the bearing Ask for a detailed drawing of the bearing, values may differ.

I.20.B

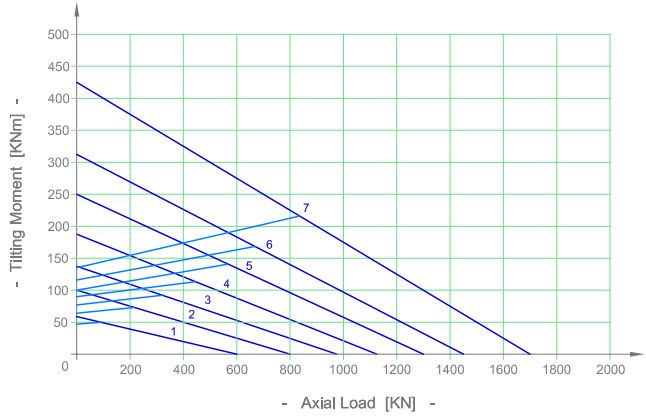
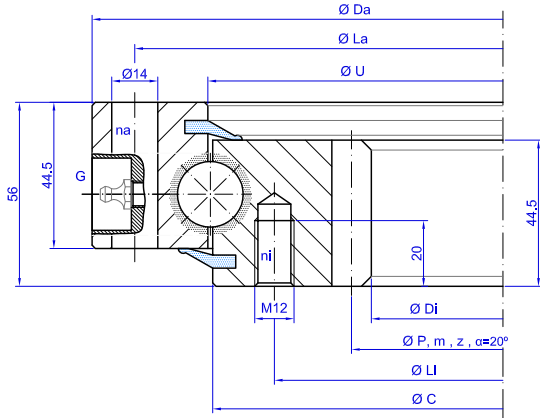

Bearing Type	Dimensions				Fixing holes				Gear teeth			Tooth Force		Mass
	Da mm	U mm	C mm	Di mm	La mm	na n°	Li mm	ni n°	P mm	m	z n°	Fz nor KN	Fz max KN	Weight KG
1 I.486.20.00.B	486	415,5	412,5	325	460	24	375	24	335	5	67	17,7	24,7	31
2 I.616.20.00.B	616	545,5	542,5	444	590	32	505	32	456	6	76	21,4	30	42
3 I.716.20.00.B	716	645,5	642,5	546	690	36	605	36	558	6	93	21,4	30	50
4 I.816.20.00.B	816	745,5	742,5	648	790	40	705	40	660	6	110	21,4	30	58
5 I.916.20.00.B	916	845,5	842,5	736	890	40	805	40	752	8	94	28,5	39,9	69
6 I.1016.20.00.B	1016	945,5	942,5	840	990	44	905	44	856	8	107	28,5	39,9	76
7 I.1166.20.00.B	1166	1095,5	1092,5	984	1140	48	1055	48	1000	8	125	28,5	39,9	91

G = N°4 x Grease nipples DIN 71412 AM 8x1 equally-spaced Ask for a detailed drawing of the bearing, values may differ.

I.25.B

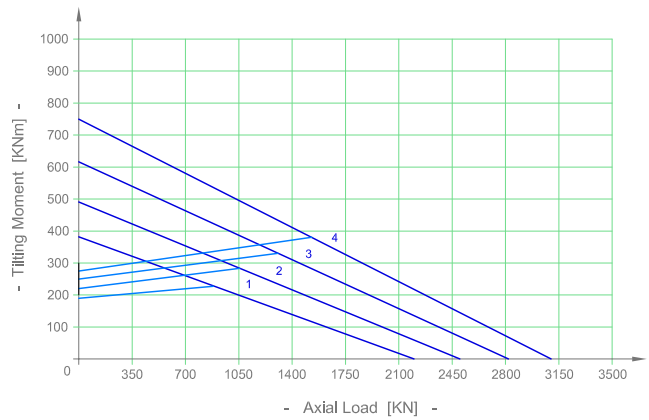
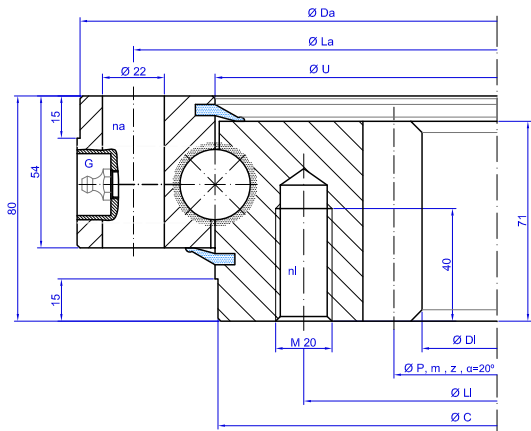

Bearing Type	Dimensions				Fixing holes				Gear teeth			Tooth Force		Mass
	Da -IT8 mm	U mm	C -IT8 mm	Di mm	La mm	na n°	Li mm	ni n°	P mm	m	z n°	Fz nor KN	Fz max KN	Weight KG
1 I.855.25.00.B	853	756	755	610	815	24	694	24	630	10	63	55,5	77,7	119
2 I.955.25.00.B	953	856	855	710	915	28	794	28	730	10	73	55,5	77,7	137
3 I.1055.25.00.B	1053	956	955	810	1015	30	894	30	830	10	83	55,5	77,7	149
4 I.1155.25.00.B	1153	1056	1055	910	1115	30	994	30	930	10	93	55,5	77,7	165

G = N°4 x Grease nipples DIN 71412 AM 10x1 equally-spaced Ask for a detailed drawing of the bearing, values may differ.

I.20.C

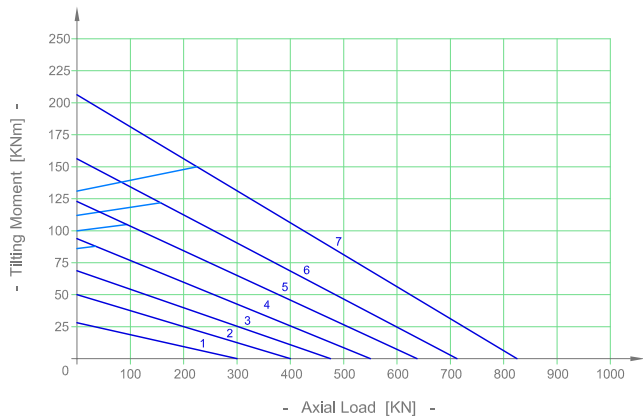
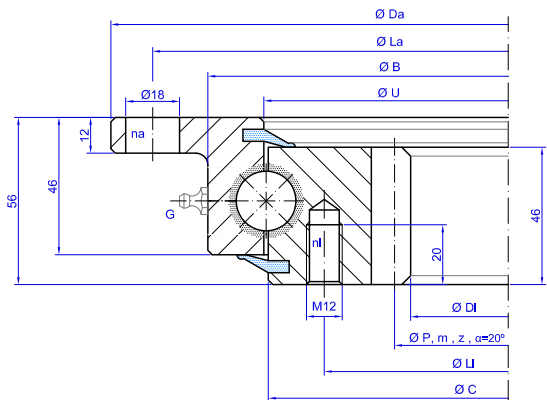

Bearing Type	Dimensions					Fixing holes				Gear teeth			Tooth Force		Mass
	Da mm	B mm	U mm	C mm	Di mm	La mm	na n°	Li mm	ni n°	P mm	m	z n°	Fz nor KN	Fz max KN	Weight KG
1 I.1505.20.00.C	518	453	415,5	412,5	326,5	490	8	375	12	335	5	67	17,7	24,7	27
2 I.1650.20.00.C	648	583	545,5	542,5	445,2	620	10	505	16	456	6	76	21,4	30	39
3 I.1750.20.00.C	748	683	645,5	642,5	547,2	720	12	605	18	558	6	93	21,4	30	46
4 I.1850.20.00.C	848	783	745,5	742,5	649,2	820	12	705	20	660	6	110	21,4	30	53
5 I.1950.20.00.C	948	883	845,5	842,5	737,6	920	14	805	20	752	8	94	28,5	39,9	63
6 I.1050.20.00.C	1048	983	945,5	942,5	841,6	1020	16	905	22	856	8	107	28,5	39,9	69
7 I.1200.20.00.C	1198	1133	1095,5	1092,5	985,6	1170	16	1055	24	1000	8	125	28,5	39,9	83

G = N°4 x Grease nipples DIN 71412 AM 8x1 equally-spaced Ask for a detailed drawing of the bearing, values may differ.

I.32.C

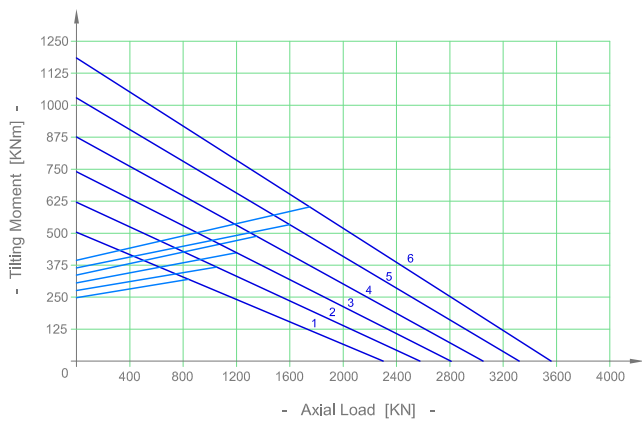
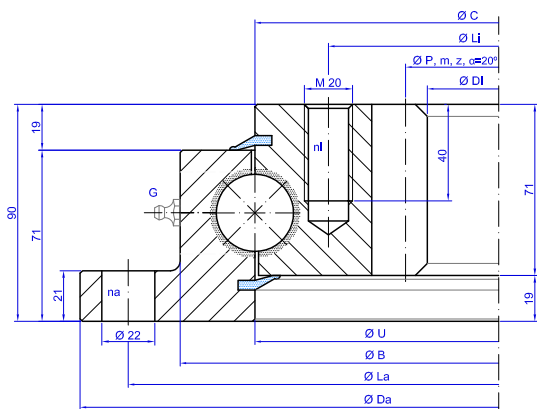

Bearing Type	Dimensions					Fixing holes				Gear teeth			Tooth Force		Mass
	Da mm	B mm	U mm	C mm	Di mm	La mm	na n°	Li mm	ni n°	P mm	m	z n°	Fz nor KN	Fz max KN	Weight KG
1 I.1100.32.00.C	1100	1017	955	955	810	1060	30	894	30	830	10	83	56,8	79,5	159
2 I.1200.32.00.C	1200	1117	1055	1055	910	1160	30	994	30	930	10	93	56,8	79,5	176
3 I.1300.32.00.C	1300	1217	1155	1155	1010	1260	36	1094	36	1030	10	103	56,8	79,5	192
4 I.1400.32.00.C	1400	1317	1255	1255	1110	1360	42	1194	42	1130	10	113	56,8	79,5	208
5 I.1500.32.00.C	1500	1417	1355	1355	1210	1460	42	1294	42	1230	10	123	56,8	79,5	226
6 I.1600.32.00.C	1600	1517	1455	1455	1310	1560	48	1394	48	1330	10	133	56,8	79,5	243

G = N°6 x Grease nipples DIN 71412 AM 10x1 equally-spaced Ask for a detailed drawing of the bearing, values may differ.

I.16-22-D

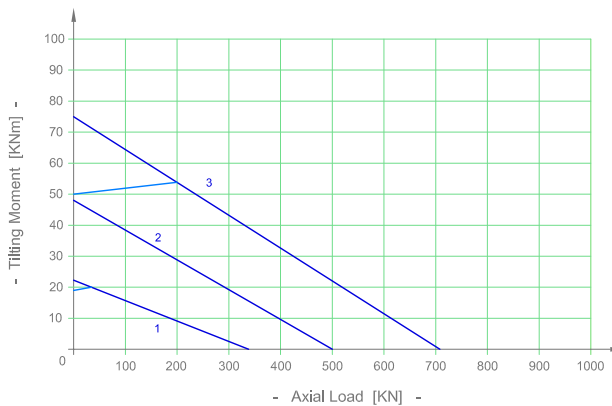
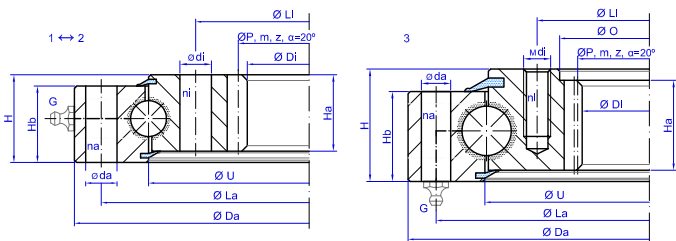

Bearing Type	Dimensions							Fixing holes					Gear teeth			Tooth Force		Mass		
	Da mm	U mm	O mm	Di mm	Ha mm	Hb mm	H mm	La mm	na n°	da mm	Li mm	ni n°	di mm	P mm	m	z n°	Fz nor KN	Fz max KN	Weight KG	
1	1.340.16.00.D.1	340	288	-	216	34	34	39	324	20	9	252	20	9	224	4	56	10,7	14,9	12
2	1.486.16.00.D.1	486	421,5	-	332	34	34	39	462	16	14	378	16	14	340	4	85	10,7	14,9	24
3	1.535.22.00.D.3-V	535	466.5	400	380	40	40	50	510	16	13	420	16	M12x1,25	384	4	96	11	22	32

1 + 2 — G = N°2 x Grease nipples DIN 71412 A M10x1 equally spaced
 3 — G = N°1 x Grease nipples DIN 71412 A M10x1 equally spaced

Ask for a detailed drawing of the bearing, values may differ.

I.25.D

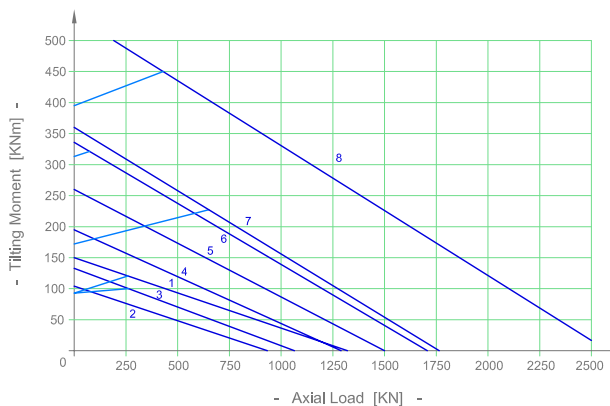
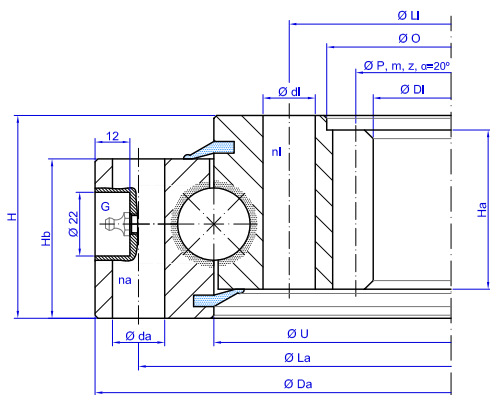

Bearing Type	Dimensions							Fixing holes					Gear teeth			Tooth Force		Mass		
	Da mm	U mm	O mm	Di mm	Ha mm	Hb mm	H mm	La mm	na n°	da mm	Li mm	ni n°	di mm	P mm	m	z n°	Fz nor KN	Fz max KN	Weight KG	
1	1.562.25.15.D.1	560	489	418	385	43	50	60	538	30	14	440	30	14	396	6	66	25,5	36,5	41
2	1.570.25.00.D.1	570	488	410	378	55	55	70	540	18	18	436	18	18	390	6	65	25,7	35,9	54
3	1.635.25.00.D.3-V	635	547	467	439,5	50	50	60	605	24	15	490	16	M16	444	6	74	30,9	43,3	57
4	1.750.25.00.D.1	750	663	575	546	55	55	70	720	20	18	605	20	18	558	6	93	26,4	37	76
5	1.850.25.00.D.1	850	762	677	648	55	55	70	820	24	18	705	24	18	660	6	110	24,9	34,9	91
6	1.950.25.00.D.1	950	862	775	736	55	55	70	920	30	18	805	30	18	752	8	94	33,3	46,6	108
7	1.980.25.00.D.3	975	892	-	784	72	66	84	944	36	18	850	36	M16	800	8	100	43,6	61	135
8	1.1015.25.15.D.1	1015	920	824	784	67	66	82	980	40	18	860	40	18	800	8	100	43,1	61,7	143

G = For the number and the position of the grease nipples, please ask for a detailed drawing of the bearing

Ask for a detailed drawing of the bearing, values may differ.

I.32.D

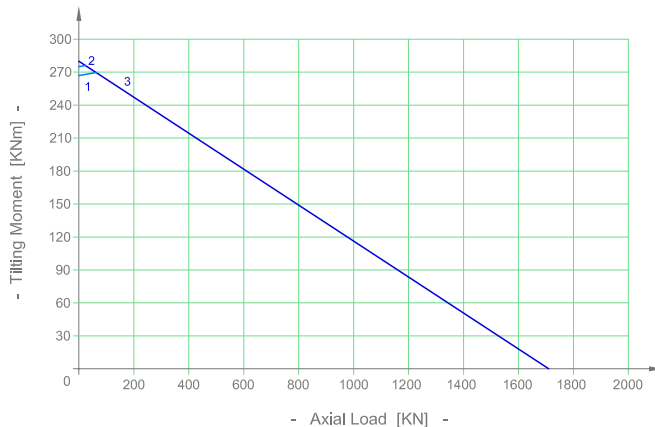
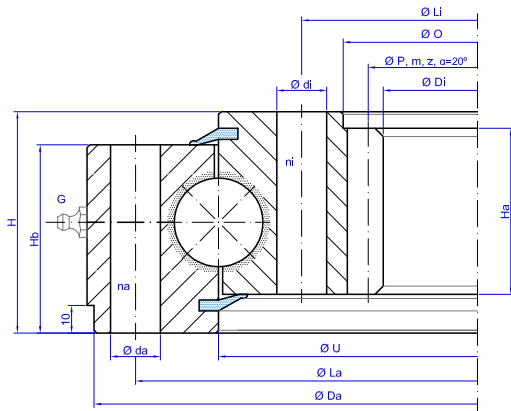

Bearing Type	Dimensions							Fixing holes					Gear teeth			Tooth Force		Mass	
	Da mm	U mm	O mm	Di mm	Ha mm	Hb mm	H mm	La mm	na n°	da mm	Li mm	ni n°	di mm	P mm	m	z n°	Fz nor KN	Fz max KN	Weight KG
1 I.810.32.00.D.1	805	718	630	601	60	68	80	780	20	18	660	20	18	612	6	102	28,8	40,3	110
2 I.815.32.10.D.1	810	720	630	593	60	68	80	780	30	18	660	30	18	608	8	76	37,9	53,1	110
3 I.816.32.10.D.1	815	715	605	568,9	67	75	90	785	18	17	640	18	17	574	7	82	37	51,8	143

G = For the number and the position of the grease nipples, please ask for a detailed drawing of the bearing Ask for a detailed drawing of the bearing, values may differ.

I.2.22-25-30.D

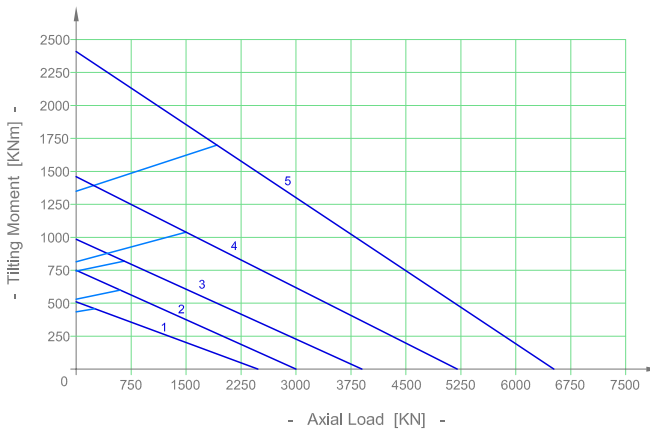
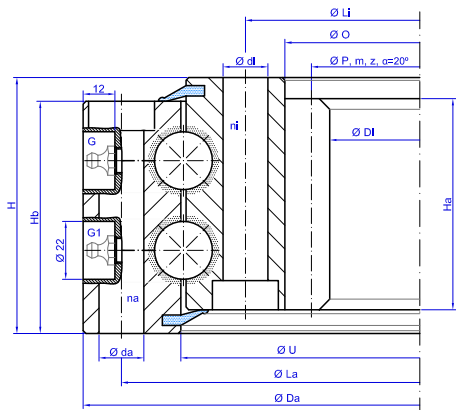

Bearing Type	Dimensions							Fixing holes					Gear teeth			Tooth Force		Mass	
	Da mm	U mm	O mm	Di mm	Ha mm	Hb mm	H mm	La mm	na n°	da mm	Li mm	ni n°	di mm	P mm	m	z n°	Fz nor KN	Fz max KN	Weight KG
1 I.973.2.22.00.D.6	973	899	820	786	80	88	97	944	36	17	850	36	17	800	8	100	36,2	72,4	141
2 I.1165.2.22.00.D.6	1165	1089	1010	962	83	88	98	1134	36	17	1040	36	17	980	10	98	45	90	187
3 I.1200.2.25.00.D.6	1200	1102	1010	963,5	88	96	110	1160	36	21	1040	36	21	980	10	98	71	99	230
4 I.1346.2.30.05.D.6	1345	1225	1115	1061,6	88	98	108	1290	48	21	1150	48	21	1080	10	108	68,9	137,8	326
5 I.1750.2.30.20.D.6	1750	1617	1470	1418	98	110	120	1705	48	25	1525	48	25	1440	12	120	95	140	567

G = For the number and the position of the grease nipples, please ask for a detailed drawing of the bearing Ask for a detailed drawing of the bearing, values may differ.

I.18-25.D-R

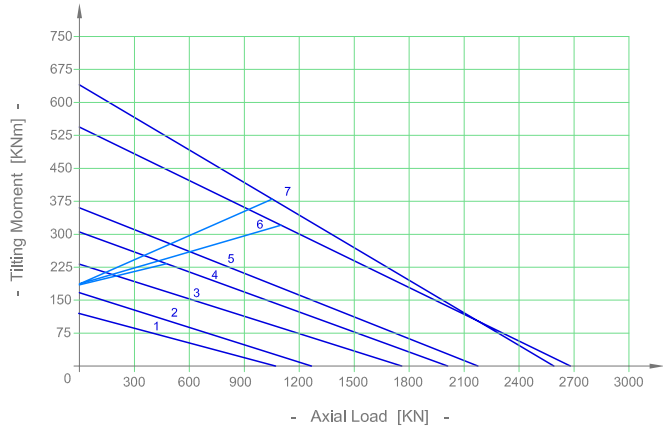
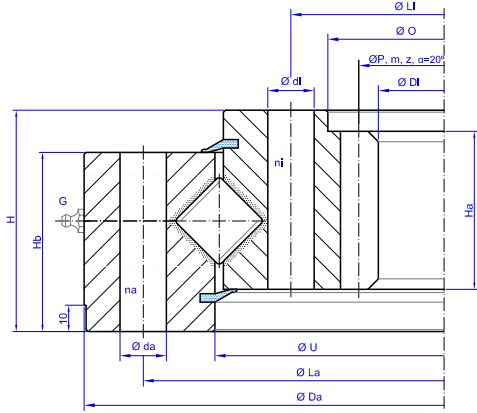

Bearing Type	Dimensions							Fixing holes					Gear teeth			Tooth Force		Mass	
	Da mm	U mm	O mm	Di mm	Ha mm	Hb mm	H mm	La mm	na n°	da mm	Li mm	ni n°	di mm	P mm	m	z n°	Fz nor KN	Fz max KN	Weight KG
1 I.1562.18.15.D.1-RV	562	490	418	384,6	45	50	60	538	30	14	440	30	14	396	6	66	15,2	30,4	44
2 I.1665.18.15.D.1-RV	665	577,5	485	457	45	50	60	630	28	18	517	28	18	462	6	77	23,4	46,8	62
3 I.1695.25.15.D.1-RV	695	578,5	472	446	53	69	85	640	30	21	508	30	21	456	6	76	24,8	49,6	83
4 I.1750.25.15.D.3-RV	750	665,5	-	546	70	66	82	720	20	17	605	20	M16	558	6	93	18,7	37,4	98
5 I.1815.25.15.D.1-RV	815	723,5	630	593	60	68	80	780	30	18	660	30	18	608	8	76	31,3	62,6	110
6 I.1976.25.15.D.5-RV	976	888	820	786	63	66	82	944	36	M16	850	36	M16	800	8	100	40	56	124
7 I.1165.25.12.D.3-RV	1175	1077,5	1010	961	62	75	90	1134	36	18	1040	36	M16	980	10	98	45	60	155

G = For the number and the position of the grease nipples, please ask for a detailed drawing of the bearing Ask for a detailed drawing of the bearing, values may differ.

I.30-40-50.D-R

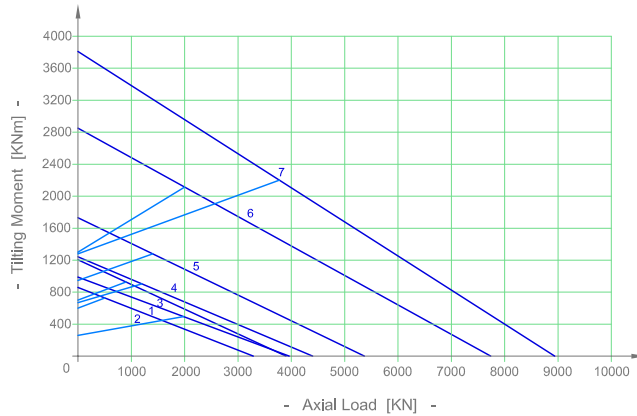
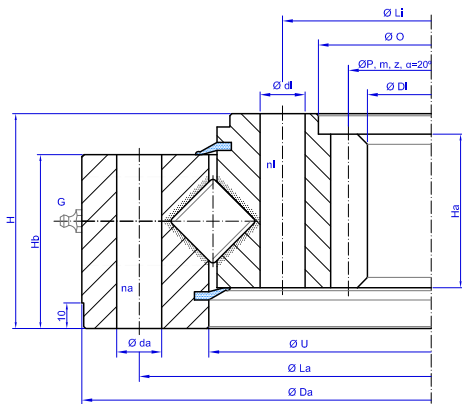

Bearing Type	Dimensions							Fixing holes					Gear teeth			Tooth Force		Mass	
	Da mm	U mm	O mm	Di mm	Ha mm	Hb mm	H mm	La mm	na n°	da mm	Li mm	ni n°	di mm	P mm	m	z n°	Fz nor KN	Fz max KN	Weight KG
1 I.1200.30.15.D.3-RV	1200	1092	1010	963,5	90	85	108	1160	36	22	1040	36	M20	980	10	98	58,6	117,2	248
2 I.1251.30.12.D.1-RV	1251	1142	-	979	75	75	91	1212	40	22	1068	36	22	990	10	99	58	116	240
3 I.1346.30.15.D.1-RV	1346	1222	1115	1067	75	85	105	1290	36	22	1150	42	22	1080	10	108	58	116	300
4 I.1460.30.12.D.1-RV	1460	1350	1230	1173	80	84	102	1425	36	22	1270	36	22	1176	12	98	74	148	365
5 I.1530.40.12.D.1-RV	1530	1410	1240	1186	90	107	130	1480	36	26	1290	36	26	1200	10	120	70	140	560
6 I.1790.50.10.D.1-RV	1790	1614	1440	1375	110	125	150	1725	48	31	1500	48	31	1400	14	100	120	240	845
7 I.2025.45.15.D.1-RV	2025	1863	1695	1619	115	118	140	1970	36	30	1780	36	30	1616	16	101	135	270	960

G = For the number and the position of the grease nipples, please ask for a detailed drawing of the bearing Ask for a detailed drawing of the bearing, values may differ.

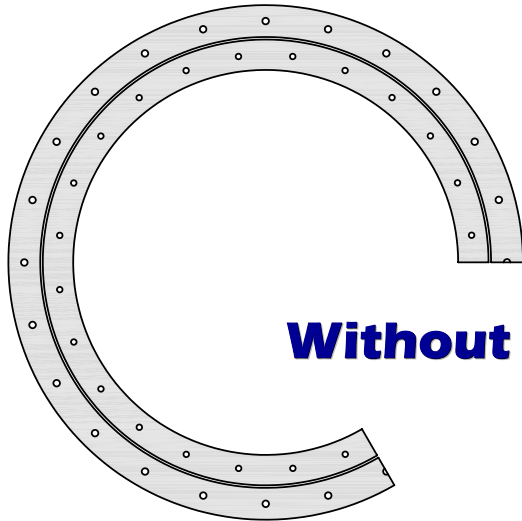

Without gear

SD.20.B

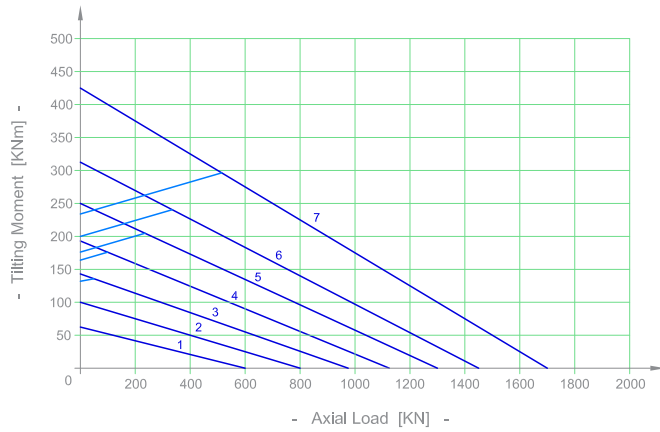
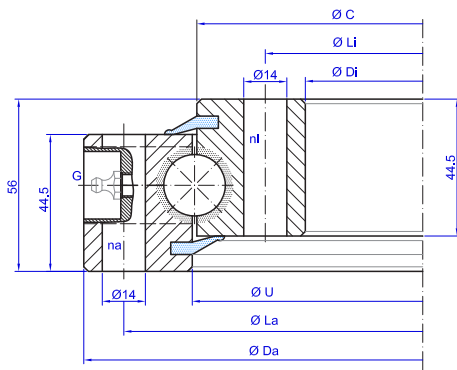

Bearing Type	Dimensions				Fixing holes				Mass
	Da mm	U mm	C mm	Di mm	La mm	na n°	Li mm	ni n°	Weight KG
1 SD.486.20.00.B	486	415,5	412,5	342	460	24	368	24	29
2 SD.616.20.00.B	616	545,5	542,5	472	590	32	498	32	37
3 SD.716.20.00.B	716	645,5	642,5	572	690	36	598	36	44
4 SD.816.20.00.B	816	745,5	742,5	672	790	40	698	40	52
5 SD.916.20.00.B	916	845,5	842,5	772	890	40	798	40	60
6 SD.1016.20.00.B	1016	945,5	942,5	872	990	44	898	44	67
7 SD.1166.20.00.B	1166	1095,5	1092,5	1022	1140	48	1048	48	77

G = N°4 x Grease nipples DIN 71412 AM 8x1 equally-spaced Ask for a detailed drawing of the bearing, values may differ.

SD.25.B

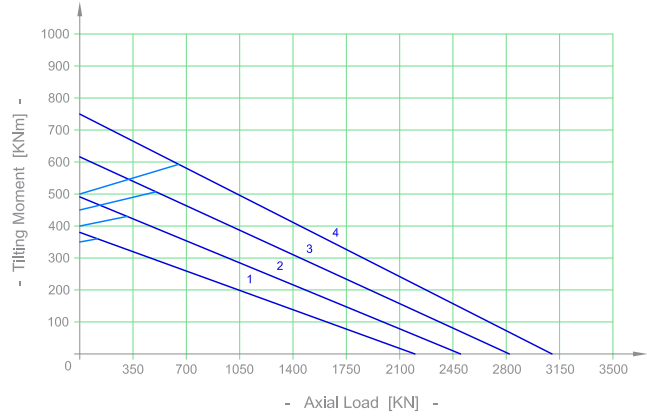
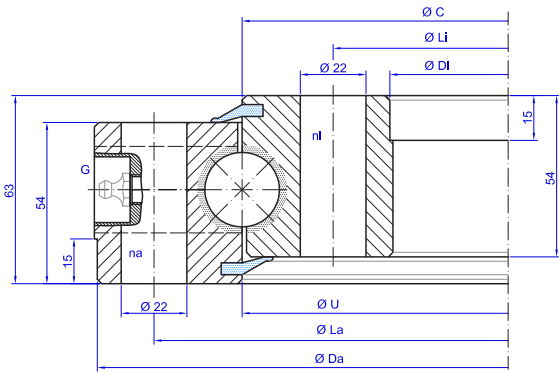

Bearing Type	Dimensions				Fixing holes				Mass
	Da mm	U mm	C mm	Di mm	La mm	na n°	Li mm	ni n°	Weight KG
1 SD.855.25.00.B	853	756	756	657	815	24	695	24	90
2 SD.955.25.00.B	953	856	856	757	915	28	795	28	101
3 SD.1055.25.00.B	1053	956	956	857	1015	30	895	30	115
4 SD.1155.25.00.B	1153	1056	1056	957	1115	30	995	30	128

G = N°4 x Grease nipples DIN 71412 AM 8x1 equally-spaced Ask for a detailed drawing of the bearing, values may differ.

SD.20.C

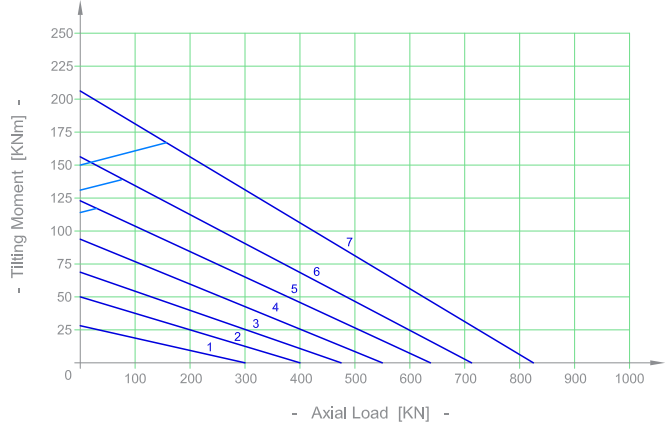
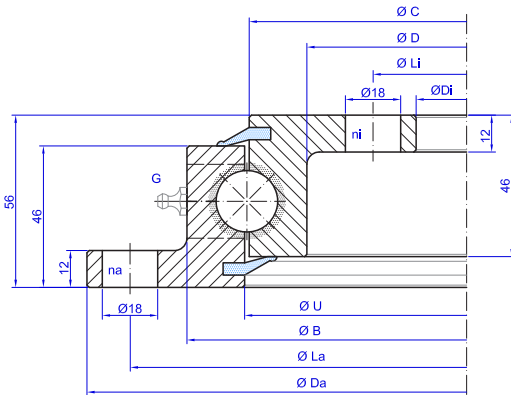

Bearing Type	Dimensions					Fixing holes				Mass	
	Da mm	B mm	U mm	C mm	D mm	Di mm	La mm	na n°	Li mm	ni n°	Weight KG
1 SD.505.20.00.C	518	453	415,5	412,5	375	304	490	8	332	12	23,5
2 SD.650.20.00.C	648	583	545,5	542,5	505	434	620	10	462	14	31
3 SD.750.20.00.C	748	683	645,5	642,5	605	534	720	12	562	16	36,5
4 SD.850.20.00.C	848	783	745,5	742,5	705	634	820	12	662	16	43
5 SD.950.20.00.C	948	883	845,5	842,5	805	734	920	14	762	18	48
6 SD.1050.20.00.C	1048	983	945,5	942,5	905	834	1020	16	862	20	54
7 SD.1200.20.00.C	1198	1133	1095,5	1092,5	1055	984	1170	16	1012	20	63

G = N°4 x Grease nipples DIN 71412 AM 8x1 equally-spaced Ask for a detailed drawing of the bearing, values may differ.

SD.32.C

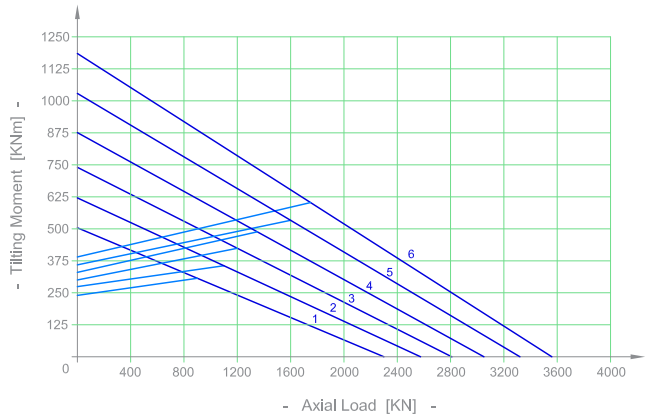
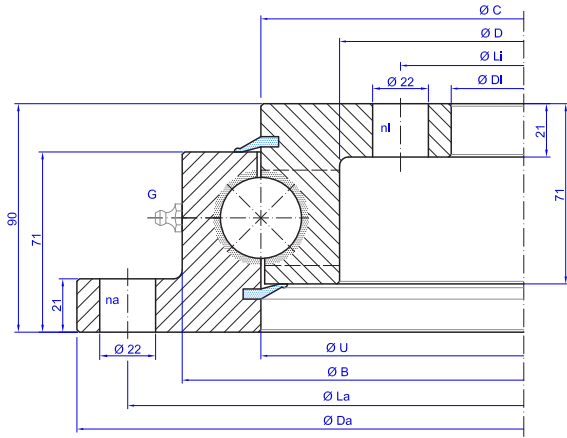

Bearing Type	Dimensions					Fixing holes					Mass
	Da mm	B mm	U mm	C mm	D mm	Di mm	La mm	na n°	Li mm	ni n°	Weight KG
1 SD.1100.32.00.C	1100	1017	955	955	893	805	1060	30	845	30	131
2 SD.1200.32.00.C	1200	1117	1055	1055	993	905	1160	30	945	30	145
3 SD.1300.32.00.C	1300	1217	1155	1155	1093	1005	1260	36	1045	36	159
4 SD.1400.32.00.C	1400	1317	1255	1255	1193	1105	1360	42	1145	42	172
5 SD.1500.32.00.C	1500	1417	1355	1355	1293	1205	1460	42	1245	42	186
6 SD.1600.32.00.C	1600	1517	1455	1455	1393	1305	1560	48	1345	48	200

G = N°4 x Grease nipples DIN 71412 AM 8x1 equally-spaced Ask for a detailed drawing of the bearing, values may differ.

SD.14-20-25.D

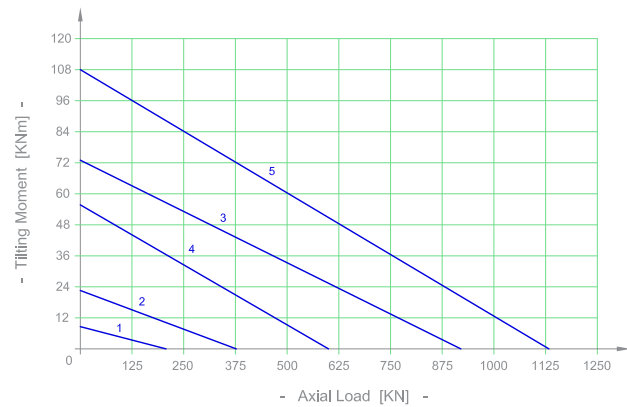
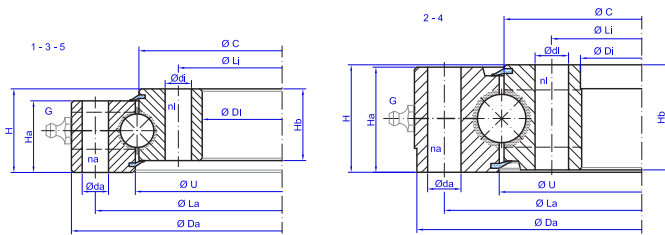

Bearing Type	Dimensions							Fixing holes						Mass
	Da mm	U mm	C mm	Di mm	Ha mm	Hb mm	H mm	La mm	na n°	da mm	Li mm	ni n°	di mm	Weight KG
1 SD.234.14.00.D.1	234	180,5	177,5	124,5	30	30	35	214	24-1	11	144,5	20	11	7
2 SD.329.20.00.D.1	327	262	258	192	44	44	45	305	16	14	215	16-1	14	18
3 SD.430.25.15.D.1	430	348	342	260	53	53	65	400	24	14	290	20	16	32
4 SD.475.20.00.D.1	474	404	403	336	44	44	45	450	24	14	360	24	14	30
5 SD.505.25.15.D.6	505	416,5	413,5	325	64,5	60	66	475	24	17	355	24	17	48

G = Number and position of the grease nipples, ask for a detailed drawing of the bearing Ask for a detailed drawing of the bearing, values may differ.

SD.18.D-R

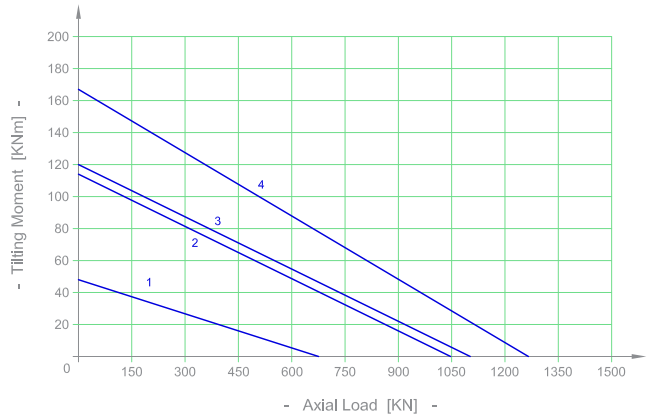
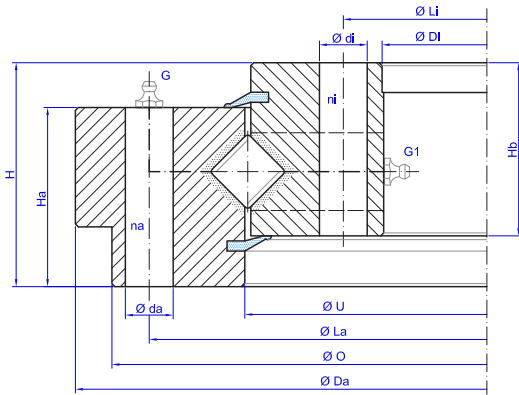

Bearing Type	Dimensions							Fixing holes					Mass	
	Da mm	O mm	U mm	Di mm	Ha mm	Hb mm	H mm	La mm	na n°	da mm	Li mm	ni n°	di mm	Weight KG
1 SD.403.18.15.D.1-R	403,5	380	312	235	45	45	55	358	24	13	259	28-1	13	25
2 SD.562.18.15.D.1-R	562	560	491,5	418	50	50	60	538	30	14	440	30	14	40
3 SD.589.18.15.D.1-R	589,5	565	477,5	385	60	58	75	540	36	16	410	36-1	16	61
4 SD.695.18.15.D.1-R	695	670	577	480	64	57	77	640	36	18	508	36-1	18	80

G = Number and position of grease nipples, ask for a detailed drawing of the bearing Ask for a detailed drawing of the bearing, values may differ.

SD.25-30.D-R

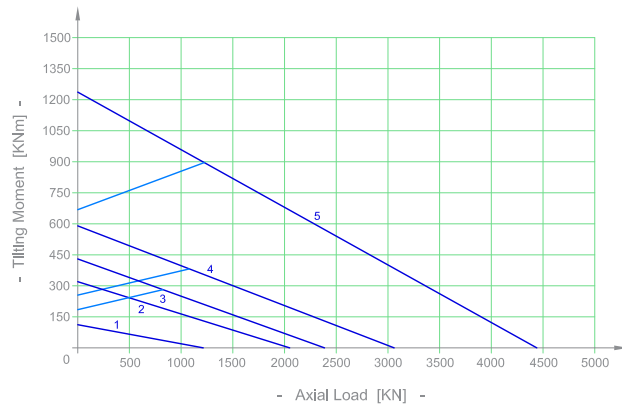
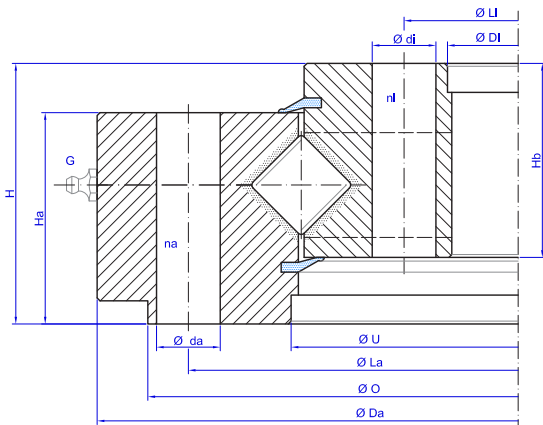

Bearing Type	Dimensions							Fixing holes					Mass	
	Da mm	O mm	U mm	Di mm	Ha mm	Hb mm	H mm	La mm	na n°	da mm	Li mm	ni n°	di mm	Weight KG
1 SD.500.25.15.D.1-R	500	495	403	307	63	63	75	466	30	18	336	30-1	18	52
2 SD.816.25.15.D.1-R	816	781	682	574	73	67	90	753	18	22	604	18	22	133
3 SD.864.25.15.D.3-R	864	833	768	678	73	68	82	802	24	M16	706	24	18	115
4 SD.979.30.15.D.1-R	979	932	845	718	79	82	100	893	36	22	753	36	22	183
5 SD.1345.30.15.D.1-R	1345	-	1223	1115	85	85	108	1290	36	22	1150	42	22	311

G = Number and position of grease nipples, ask for a detailed drawing of the bearing Ask for a detailed drawing of the bearing, values may differ.

U SERIE

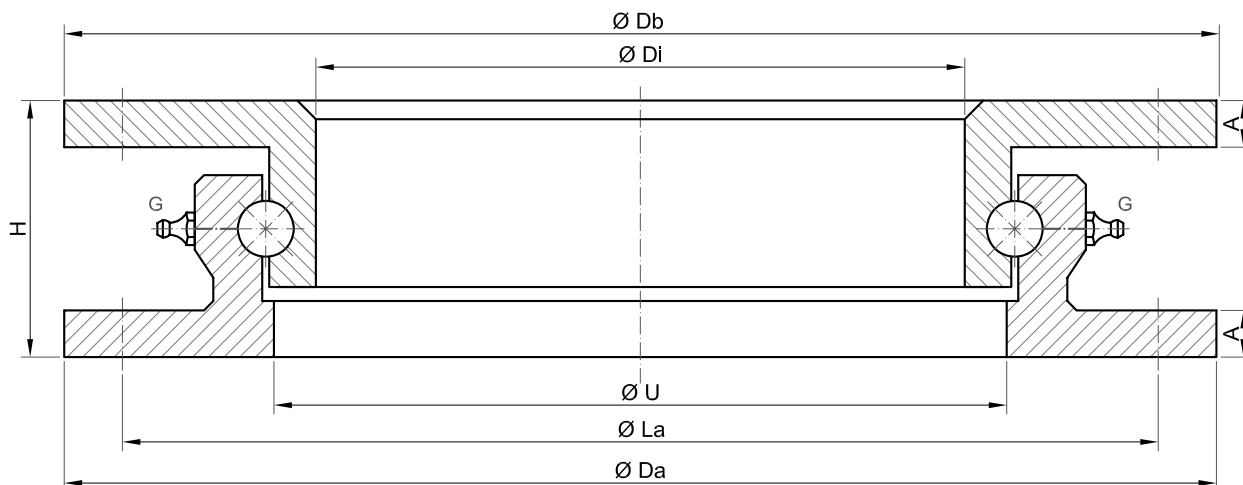

U.12 SERIES - DIMENSIONS									Diameter Ball: 12.70 mm	
	Da (mm)	Db (mm)	U (mm)	Di (mm)	La (mm)	H (mm)	A (mm)	G (n°)	Axial Load (KN)	Weight (Kg)
U.300.12	295	295	220	200	270	55	10	1	5	6
U.400.12	400	400	310	292	375	55	10	1	7.5	8
U.500.12	500	500	410	392	475	55	10	1	10	10

U.14 SERIES - DIMENSIONS									Diameter Ball: 14.288mm	
	Da (mm)	Db (mm)	U (mm)	Di (mm)	La (mm)	H (mm)	A (mm)	G (n°)	Axial Load (KN)	Weight (Kg)
U.600.14	600	600	510	485	575	65	10	2	17	18
U.650.14	650	650	560	535	625	65	10	2	19	20
U.700.14	700	700	610	585	675	65	10	2	22	22
U.750.14	750	750	660	635	725	65	10	2	24	24
U.800.14	800	800	710	685	775	65	10	2	27	26
U.850.14	850	850	760	735	825	65	10	2	31	28
U.900.14	900	900	810	785	875	65	10	2	35	30
U.950.14	950	950	860	835	925	65	10	2	37	32
U.1000.14	1000	1000	910	885	975	65	10	2	40	34
U.1050.14	1050	1050	960	935	1025	65	10	2	45	36
U.1100.14	1100	1100	1010	985	1075	65	10	2	48	38

U.16 SERIES - DIMENSIONS									Diameter Ball: 15.875mm	
	Da (mm)	Db (mm)	U (mm)	Di (mm)	La (mm)	H (mm)	A (mm)	G (n°)	Axial Load (KN)	Weight (Kg)
U.895.16	890	895	780	762	852	80	12	2	50	36
U.1015.16	1010	1015	900	882	972	80	12	2	60	43
U.1105.16	1100	1105	990	972	1060	80	12	2	65	50

Z SERIE

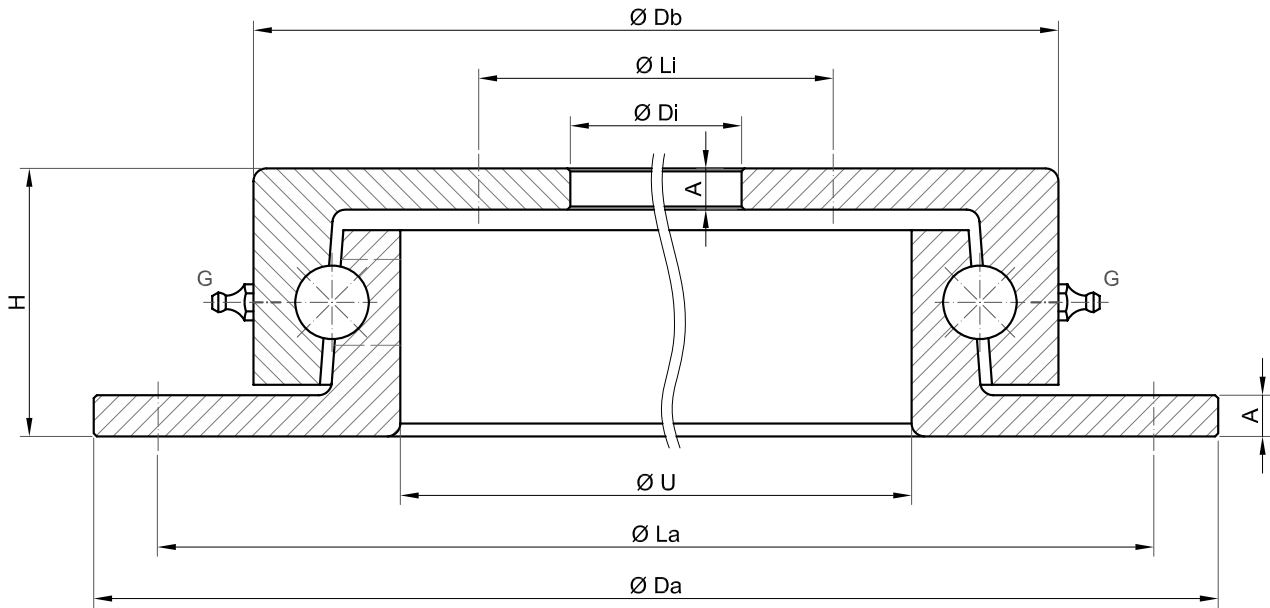

Z.14 SERIES - DIMENSIONS

Diameter Ball: 14.288mm

	Da (mm)	Di (mm)	Db (mm)	U (mm)	La (mm)	Li (mm)	H (mm)	A (mm)	G (n°)	Axial Load (KN)	Weight (Kg)
Z.400.14	400	215	334	281	375	260	52	8	4	14	14
Z.500.14	500	315	434	381	475	340	52	8	4	18	18
Z.650.14	650	465	584	531	625	490	52	8	4	25	24

Z.16 SERIES - DIMENSIONS

Diameter Ball: 15.875mm

	Da (mm)	Di (mm)	Db (mm)	U (mm)	La (mm)	Li (mm)	H (mm)	A (mm)	G (n°)	Axial Load (KN)	Weight (Kg)
Z.750.16	750	565	687	623	725	590	52	10	4	30	28
Z.850.16	850	665	787	723	825	690	52	10	4	35	33
Z.950.16	950	765	887	823	925	790	52	10	4	40	36
Z.1050.16	1050	865	987	923	1025	890	52	10	4	50	42

ACCESSORIES - PINION DRIVE

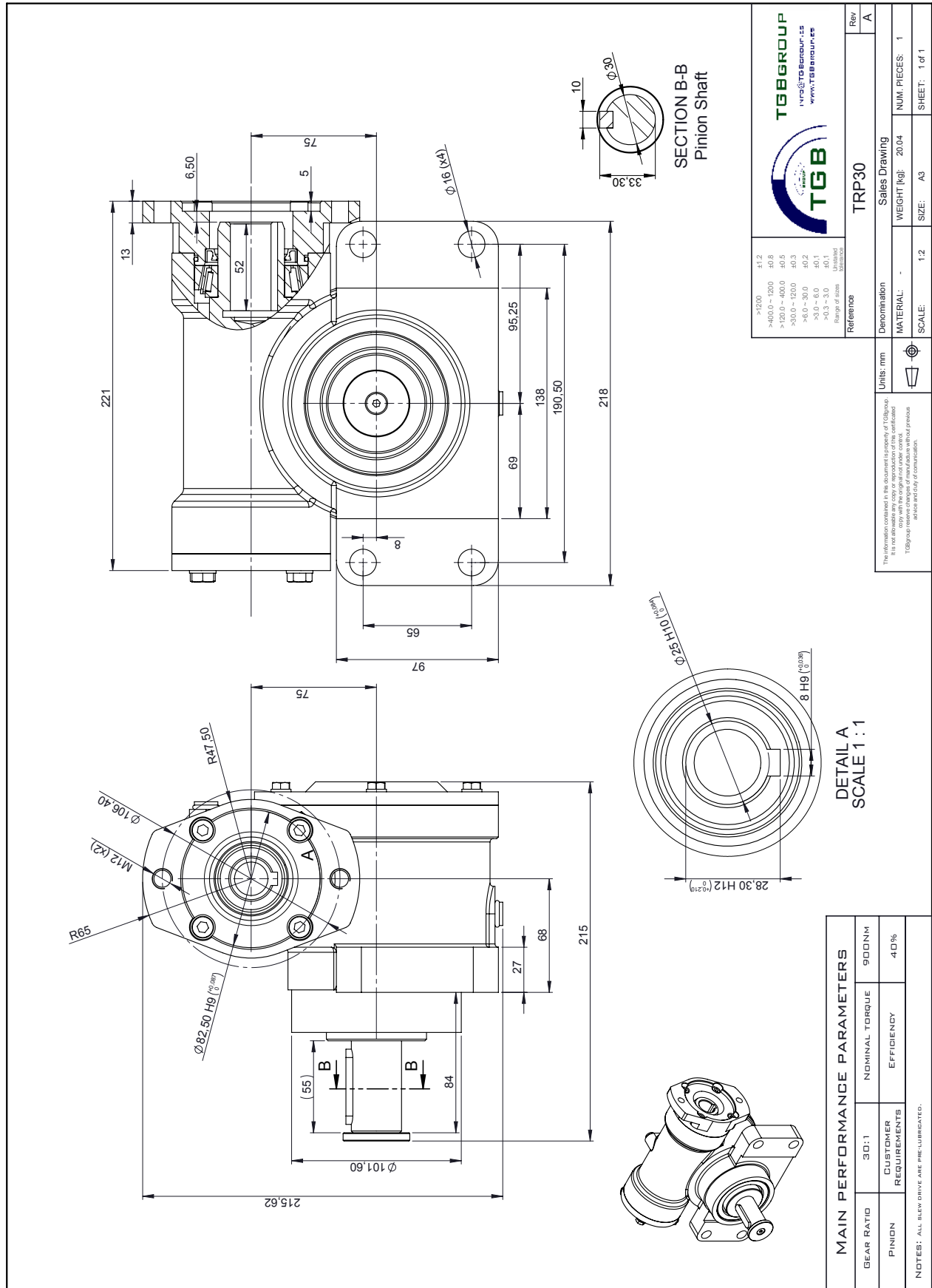

 TGB GROUP INFO@TGBGROUP.COM WWW.TGBGROUP.COM		Rev	A
Reference >1200 ±1.2 >400.0 - 1200 ±0.8 >120.0 - 400.0 ±0.5 >30.0 - 120.0 ±0.3 >6.0 - 30.0 ±0.2 >3.0 - 6.0 ±0.1 >0.3 - 3.0 ±0.1 Range of sizes Minimum		Denomination	TRP30
Units: mm <small>The information contained in this document is the property of TGB Group. It is not to be used, copied, reproduced, or disseminated without the prior written consent of TGB Group. TGB Group reserves the right to modify specifications without previous notice.</small>		Sales Drawing	
MATERIAL:		WEIGHT (kg)	20.04
SCALE:		SIZE:	A3
NUM. PIECES:		1	
SHEET:		1 of 1	

MAIN PERFORMANCE PARAMETERS			
GEAR RATIO	30:1	NOMINAL TORQUE	900NM
PINION	CUSTOMER REQUIREMENTS	EFFICIENCY	40%

NOTES: ALL BEV DRIVE ARE PRE-LUBRICATED.

we *move*

Your movement solutions



TGBGROUP
(HEADQUARTERS)

C/ L'Alsina, Parcela 37 - Nave 3
Polígono Industrial "LA MASIA"
08798 Sant Cugat Sesgarrigues
Barcelona - SPAIN

Phone: +34 938 182 450
Email: info@tgbgroup.es

TGBGROUP EUROPE B.V.

Bennebroekerweg 93 S
1435 CH Rijsenhout
The Netherlands

Phone: +31 (0) 297 268 942
Email: info@tgbgroup.es