

USER INSTRUCTIONS FOR THE WL RECEIVER-TRANSMITTER CODE MINI POWERPACK

CODE

101-050

WL
WireLess

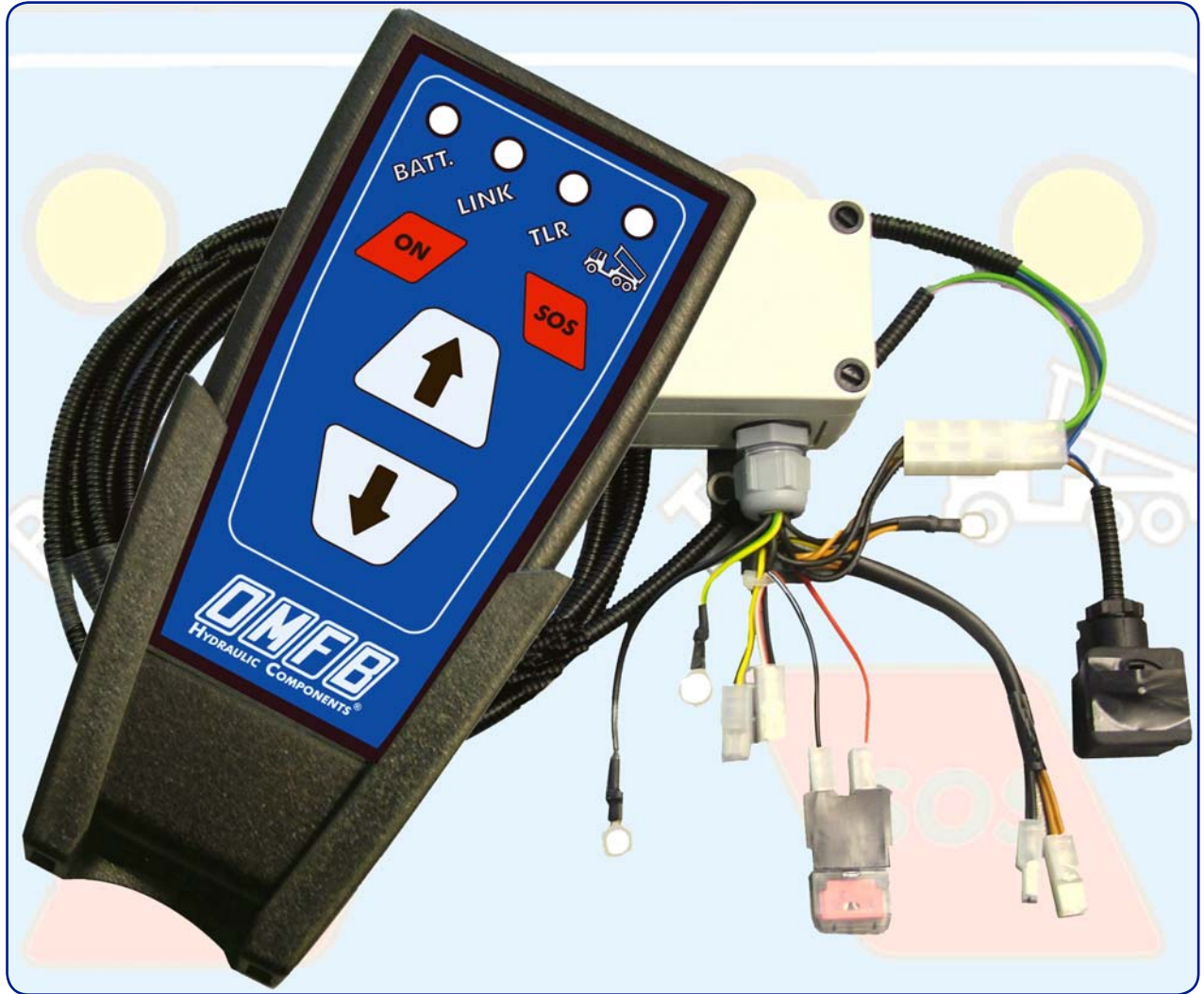

GB

Data: Mercoledì 24 luglio 2013

Codice foglio: 997-101-50346 Rev: AB

pag. 1

OMFB
HYDRAULIC COMPONENTS

O.M.F.B. S.p.A. Hydraulic Components
We reserve the right to make any changes without notice.
Edition 2010.02 No reproduction, however partial, is permitted.
Via Cave, 7/9 25050 Provaglio d'Iseo (Brescia) Italy Tel.: +39.030.9830611
Fax: +39.030.9839207-208 Internet: www.omfb.it e-mail: info@omfb.it

COMPANY WITH
QUALITY SYSTEM
CERTIFIED BY DNV GL
= ISO 9001 =

1. GENERAL NOTES	pag. 3
1.1. The RECEIVER	pag. 3
1.2. The TRANSMITTER.....	pag. 3
2. TECHNICAL SPECIFICATIONS	pag. 4
2.1 WL Transmitter Device	pag. 4
2.2 Receiver Device	pag. 4
3. GENERAL DESCRIPTION OF CONTROLS AND INDICATIONS.....	pag. 5
3.1 General Operation	pag. 5
4. SPECIFIC DESCRIPTION OF CONTROLS.....	pag. 6
4.1 ON	pag. 6
4.2 TRANSMITTER BATTERY STATE	pag. 6
4.3 CONNECTED	pag. 7
4.4 CHANGE CHANNEL	pag. 7
4.5 Capacity and several systems co-existing	pag. 7
4.6 CONTAINER RAISED	pag. 8
4.7 CONTACTOR GLUED.....	pag. 8
4.8 EMERGENCY	pag. 8
4.9 RE-ENABLING AFTER EMERGENCY.....	pag. 9
4.10 TO SUM UP.....	pag. 9
5. MANUAL OUTPUT ACTIVATION PROCEDURE.....	pag. 9
5.1 Manual activation of ascent emergency	pag. 9
5.2 Manual activation of descent emergency	pag. 10
5.3 PROGRAMMING procedure	pag. 12
6. OPTIONAL CONFIGURATION FOR FITTING A DOUBLE CONTACTO	pag. 15
7. SPARE PARTS	pag. 15
8. STRUCTURAL AND FUNCIONAL DIAGRAMS	pag. 16
8.1 Structural WIRING diagram.....	pag. 16
8.2 COMPLETE functional diagram.....	pag. 17
8.3 Configuration diagram of OPTIONAL double emergency contactor	pag. 18

IMPORTANT

"It is the responsibility of the installation technician to ensure the power supply of the remote control system and hydraulic mini powerpack is protected with a fuse and disconnect switch."

"It is the responsibility of the user to ensure the remote control system and hydraulic mini powerpack are disconnected from the power supply at the disconnect switch when the vehicle is in motion."

MANUFACTURER:

O.M.F.B. S.p.A. Hydraulic Components
 Via Cave, 7/9 25050 Provaglio d'Iseo (Brescia) Italy
 Tel.: +39.030.9830611 - Fax: +39.030.9839207-208
 Internet:www.omfb.it e-mail:info@omfb.it

The present instruction sheet refers to radio remote controls **2CH WL** and specifically to the types **2 WL RX - 2 WL TX**

1. GENERAL DATA

The control system for the WL unit consists of 2 units, both of which receive and transmit:

1.1 THE RECEIVER (2 WL RX)

Situated inside the plastic guard on electric motor, it receives commands from the TRANSMITTER and send information back to the transmitter regarding the state of control unit.

1.2 THE TRANSMITTER (2 WL TX)

As well as transmit commands, it can receive information from the receiver.



REMOTE CONTROL - CONTROL UNIT COMMUNICATIONS

- START-UP
- CONTAINER ASCENT
- CONTAINER DESCENT
- EMERGENCY



RICEVENTE RX

CONTROL UNIT - REMOTE CONTROL COMMUNICATIONS

- CONNECTION/COMMUNICATION STATE
- CONTAINER ASCENT STATE
- GLUED CONTACTOR STATE
- EMERGENCY STATE

• THE WL POWER-PRO CONTROL UNIT MANAGES:

- ON/OFF key
- Remote control for raising and lowering the tip-up
- Battery charge led on transmitter
- Contactor failure led on transmitter
- Light on transmitter if container raised
- Functions blocked due to failure through SOS key

2. TECHNICAL SPECIFICATIONS

2.1 WL TRANSMITTER DEVICE

- GFSK modulation
- Operating frequency: 2.4 GHz
- ERP RF power 1 - 3 mW
- 2 x 1.5V AAA LR03 batteries
- Receiver sensitivity - 93 dBm
- Current consumption 21 mA
- IP protection: IP 54

WARNING:

- **If batteries are replaced with wrong models it might explode.**
- **Dispose of used batteries according to applicable regulations.**



WARNING:

If the transmitter is used for remote control of a vehicle with a tipper body, the operator must not walk or stay close to the vehicle when using the equipment truck, also including the entire descent phase

2.2 RECEIVER DEVICE

VOLTAGE SUPPLY	min 9 V, max 28 V
MAXIMUM CURRENT CONSUMPTION	370 mA a 10 V 563 mA a 28 V
MAX SWITCHING CURRENT	8 A
OPERATING FREQUENCY	2.4 GHz
RF SENSITIVITY	- 93 dBm
BAND	2400 ÷ 2483 MHz
ANTENNA RF EMISSIONS	- 65 dBm
IP PROTECTION (EN 60529)	The box and buttons guarantee IP65 protection of the casing. The cabling is excluded.
OUTPUTS	N° 2 Relè
CONTACT CAPACITY	max 8 A
OPERATING TEMPERATURE	- 30 / + 80 °C

3. GENERAL DESCRIPTION OF CONTROLS AND INDICATIONS

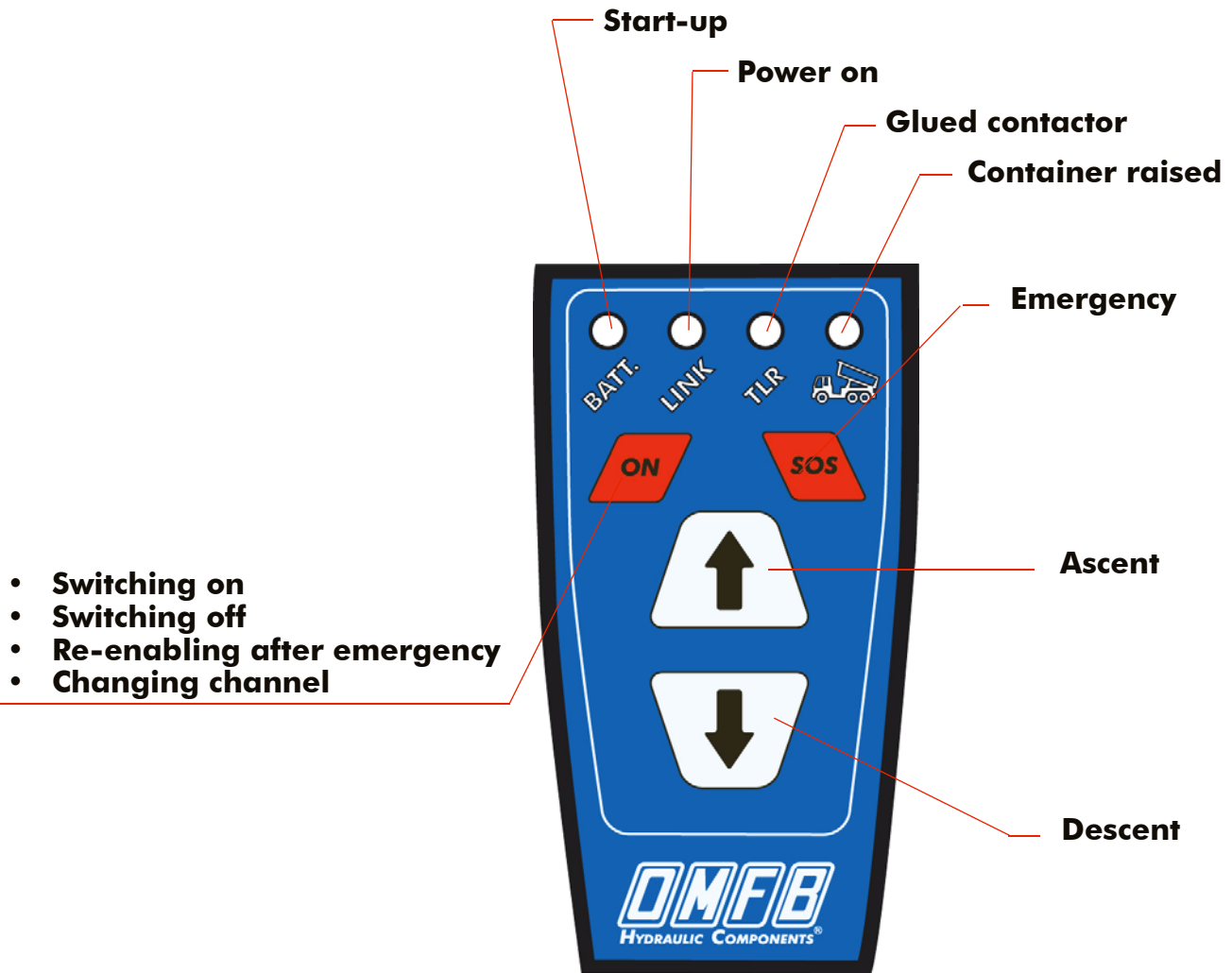

3.1 GENERAL OPERATION

Turning on the TX the system checks receiver presence and once identified and communicating the yellow "Link" led comes on. If the yellow "Link" key led does not come on when the transmitter is turned on, check that the transmitter is powered (in particular, check that the battery disconnecter on the tip-up container with mini powerpack is inserted and on). If the yellow "Link" led should go off and flash during operation, this means it is not within the max working distance allowed between the transmitter and the receiver, which is 5 metres. (For needs/applications requiring greater distances check other OMFB catalogue products). On pressing the Up key (in the picture) the following occurs: in "man present" mode (that is, output on for as long as the key is pressed) of the corresponding Up outlet which in wiring corresponds to the violet wire tension level being taken to the power voltage level. On pressing the Down key (in the picture) the following occurs: in "man present" mode (that is output on for as long as the key is pressed) of the corresponding down outlet which in wiring corresponds to the solenoid valve connector Blue wire tension level being taken to the power voltage level.

N.B. To better understand operation, refer also to the COMPLETE FUNCTIONAL DIAGRAM on page 17 of this manual.

4. SPECIFIC DESCRIPTION OF CONTROLS

The TRANSMITTER has four function led lights.

4.1 ON

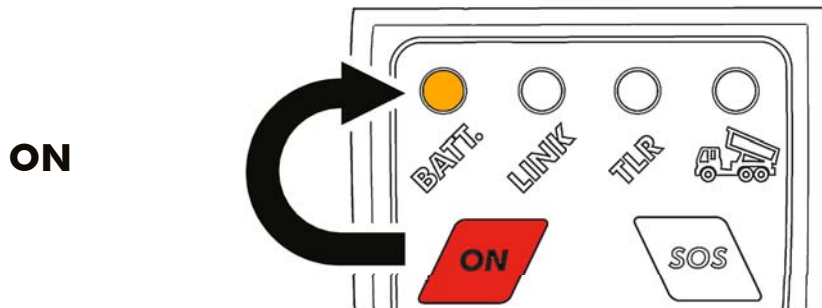

- **ON**

Pressing the red ON key, the TRANSMITTER comes on and the battery led flashes continuously for 1 second to indicate it is on. It will then flash every 3 seconds to indicate that it is working.

- **OFF**

Pressing the ON key for longer than 2 seconds the device turns off. The "BATT" led switches off, confirming the device is no longer on.

- **AUTOMATIC POWER OFF**

The TRANSMITTER turns off automatically after the keyboard has not been used for 3 minutes. Power off will be preceded by 3 to 5 consecutive flashes close to each other. This also happens when the battery is flat and, in that case, after pressing ON, the led will issue 2 long flashes and then go off.

- **POWER OFF IMPOSSIBLE**

The TRANSMITTER does not go off if:

- 1) The container is raised (in this case the TRANSMITTER led light stays on);
- 2) The contactor is glued (in this case the TRANSMITTER led light stays on);

4.2 Indications of TRANSMITTER BATTERY STATE

The battery led also indicates general battery state and is read before each transmission:

- **BATTERY CHARGED:** led flashes every 3 seconds
- **BATTERY PARTIALLY FLAT:** if the battery charge is under 2.2 Volts, the battery led will keep on flashing every second for as long as the TRANSMITTER stays on.
- **BATTERY COMPLETELY FLAT:** if the battery charge is under 1.9 Volts, the battery led will issue 2 long flashes and then go off.

The two AAA LR03 batteries last for at least 1 year with normal use of the tip-up container. To replace these, open the transmitter by undoing the screw at the back.

4.3 CONNECTED

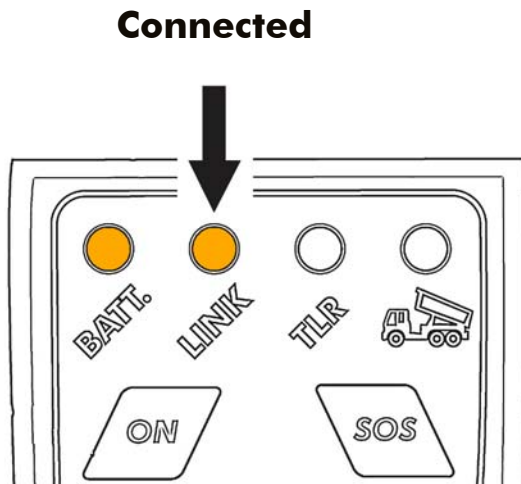

The LINK led only signals radio connection. It comes on when a TRANSMITTER –RECEIVER connection is established. If the connection should be terminated, for various reasons, the led goes off and the RECEIVER automatically places itself on emergency LINK.

4.4 CHANGE CHANNEL

When turned on the transmitter transmits on a pre-defined channel.

If that channel is not disturbed the link is made, the receiver stays on that channel and the remote control's Link led comes on.

If the channel is disturbed the Link led does not come on and the operator has to press and release the ON key which moves to a new channel.

When the ON key is released the Link led flashes fast to indicate that pressure took place and if the link is on the Link led stays on.

Before proceeding to a further channel change is necessary to wait at least 10 seconds to allow complete channel scan receiver.

The system allows you to choose between 6 different work channels by repeatedly pressing the ON button. If the mobile unit has two remote controls, it links to the first one received so, even if the second remote control is present at the same time, the latter's packages are ignored by the fixed unit.

4.5 Capacity and several systems co-existing

The system is gauged to guarantee a maximum 5 metre range of action between mobile unit (transmitter) and fixed unit (receiver).

The system was designed to guarantee, where necessary, co-existence and use of 6 systems at the same time in a 5 metre range.

Where required, the system can be supplied with a second coded transmitter.

4.6 CONTAINER RAISED

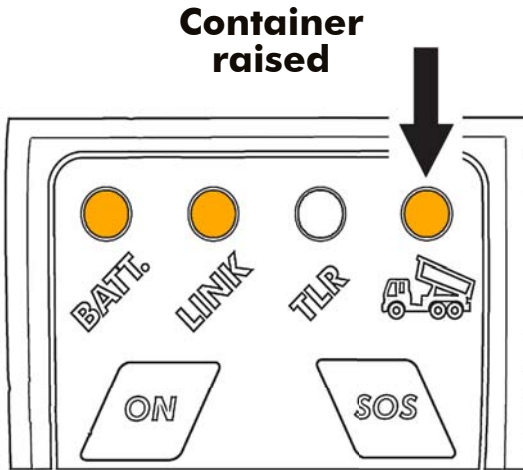

The led with the vehicle icon communicates container state. If this is raised the TRANSMITTER cannot be turned off.

ATTENTION: SIGNALLING IS INDIRECT!

The led is activated by the control unit's pressure gauge when there is pressure in the hydraulic circuit.

4.7 CONTACTOR GLUED

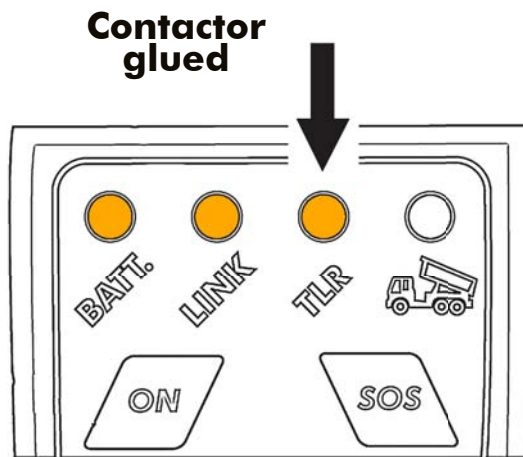

The TLR led communicates contactor state. If this is glued, the led stays on and the TRANSMITTER cannot be turned off. When the contactor is glued, act IMMEDIATELY by disconnecting the disconnector switch to prevent irreparable damage to the motor and the vehicle and/or avoid the risk of fire.

4.8 EMERGENCY indication

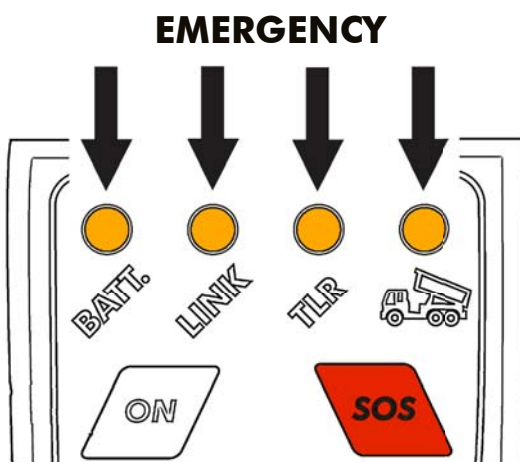

The "Emergency" key  has precedence over all other controls. Pressing this key disables any other active function. The RECEIVER communicates the emergency state to the TRANSMITTER by flashing the 4 leds together. **IMPORTANT: the EMERGENCY button is no use when the contactor is glued.**

4.9 RE-ENABLING AFTER EMERGENCY

You re-enable after emergency by pressing the ON key for longer than 2 seconds and then releasing it. Once re-enabled, indications return to the pre-emergency state. At this point the system updates and resets automatically.

If the SOS key is pressed at the same time as other keys the SOS key has priority.

4.10 TO SUM UP



- A single quick press starts the TRANSMITTER
- Pressed for longer than 2 seconds, the TRANSMITTER goes off
- Pressed for longer than 2 seconds after an emergency, the TRANSMITTER is re-enabled.
- Pressed and released quickly with the TX switched on, the radio transmission channel is changed (max 6 channels).



- It disables any output function when all 4 TRANSMITTER leds are flashing.
- You exit emergency conditions by pressing ON  for more than 2 seconds.

5. MANUAL OUTPUT ACTIVATION PROCEDURE



TO BE EXECUTED ONLY BY A COMPETENT OPERATOR – IT CAN INVOLVE AN ELEMENT OF RISK!!

5.1 MANUAL ACTIVATION OF ASCENT EMERGENCY

Eliminate the black heat-restricting protection from the Green wire indicated in the figure.

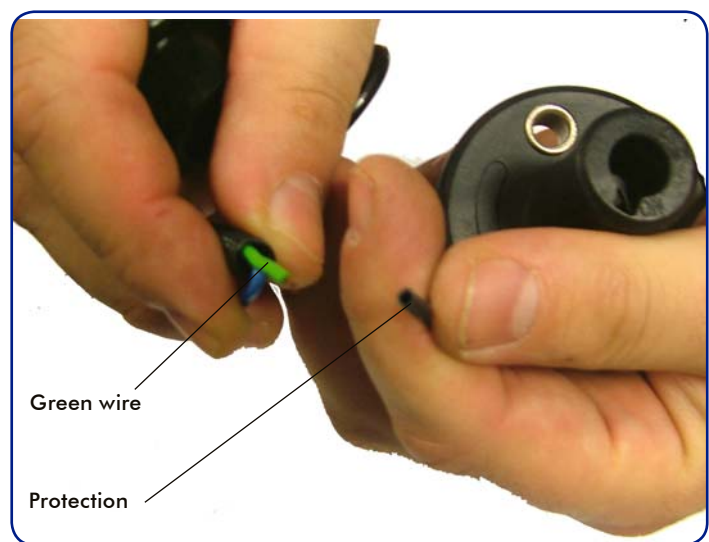
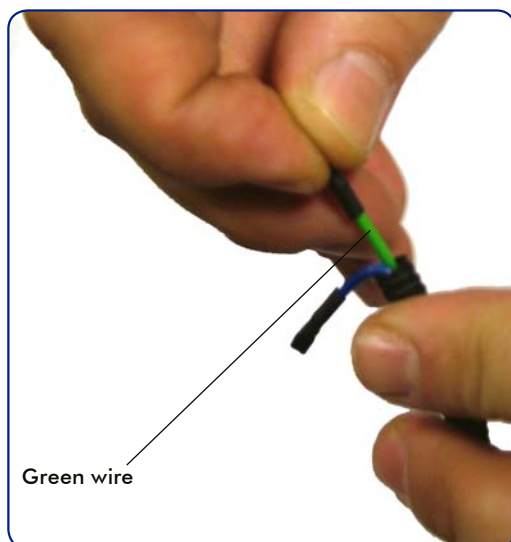

Connecting the Green wire to positive you get manual up activation.

**CAUTION!! DANGER!! The container is raised.
BE CAREFUL AS THE CONTAINER MOVES.**

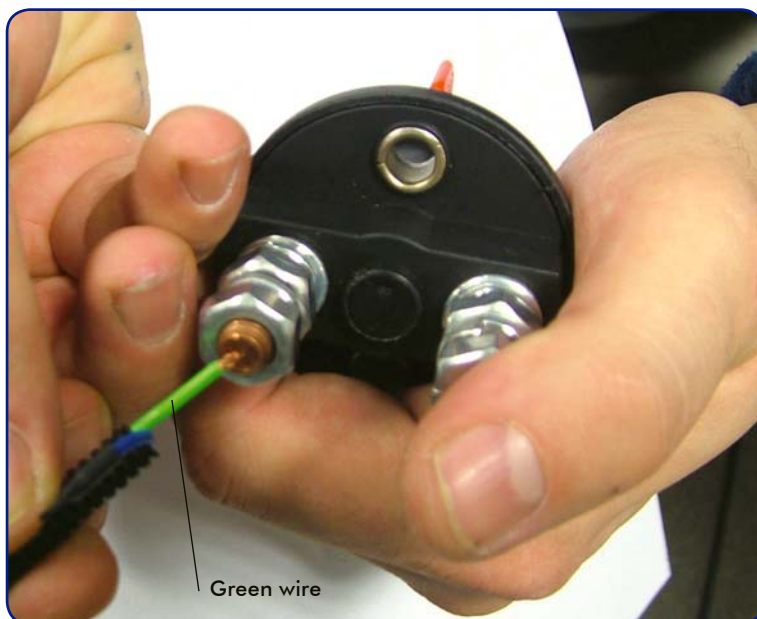

You can stop ascent by disconnecting the green wire from the positive

5.2 MANUAL ACTIVATION OF DESCENT EMERGENCY

Eliminate the black heat-restricting protection from the blue wire indicated in the figure

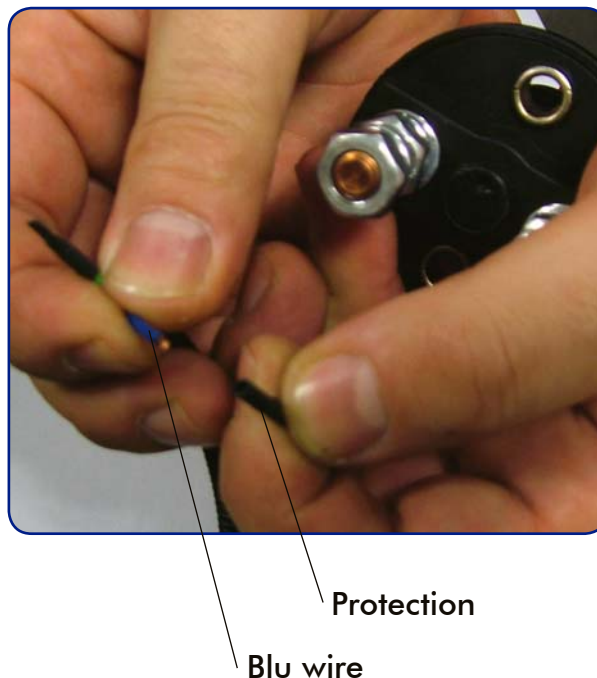
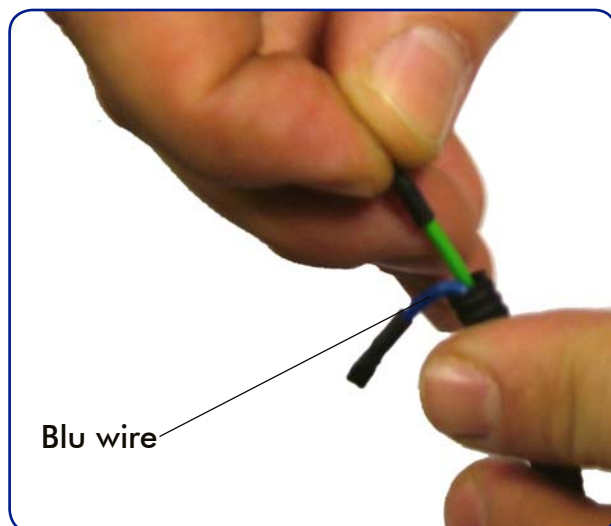

Connecting the blue wire to positive you get manual down activation.

**CAUTION!! DANGER!! The container is lowered.
BE CAREFUL AS THE CONTAINER MOVES.**



Blu wire

You can stop descent by disconnecting the blue wire from the positive.

The heat-restricting protection must be put back on both the green and blue wires at the end of all emergency operations.

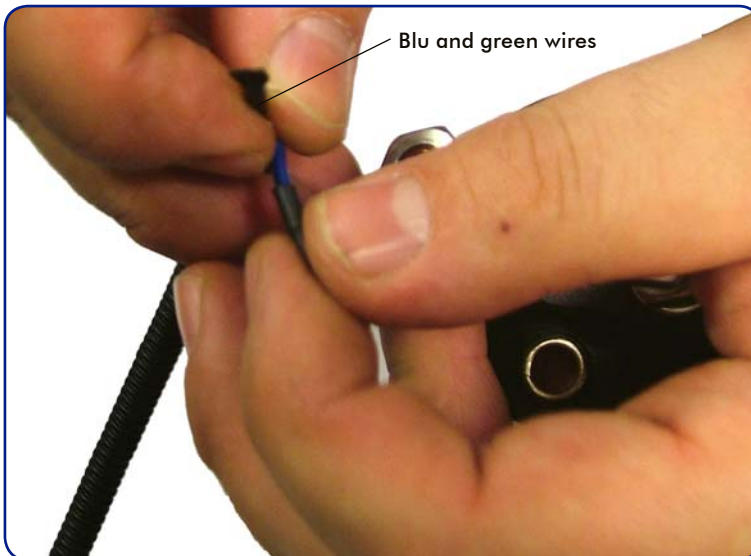

Blu and green wires



BE CAREFUL: manual up and down is potentially very dangerous and can endanger people. Said operation must only be done by trained staff and taking all precautions to avoid damage to people or property. Any consequences resulting from this procedure are the responsibility of whoever does it.

5.3 PROGRAMMING PROCEDURE

Do the following to program a new transmitter:

- 5.3.1 Make sure there are no other transmitters on within a 50 metre range.
 5.3.2 Turn receiver power off



- 5.3.3 Remove the guard on the motor of the mini powerpack



- 5.3.4 5.3.4 Disconnect the black number 6 wire from mass and connect to positive.

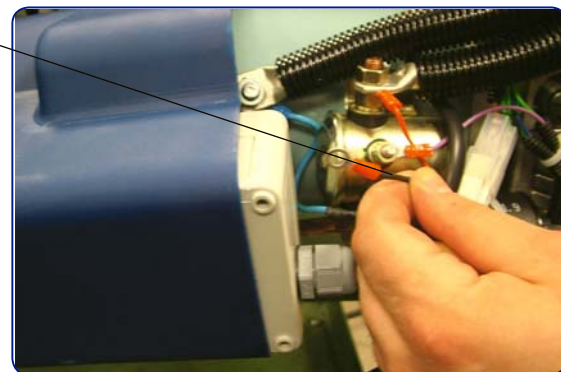
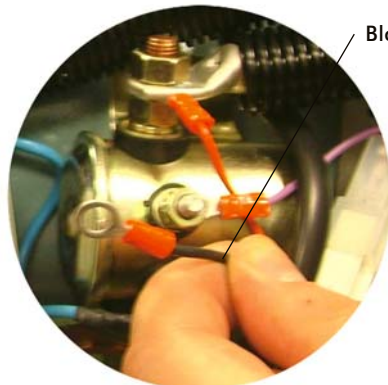
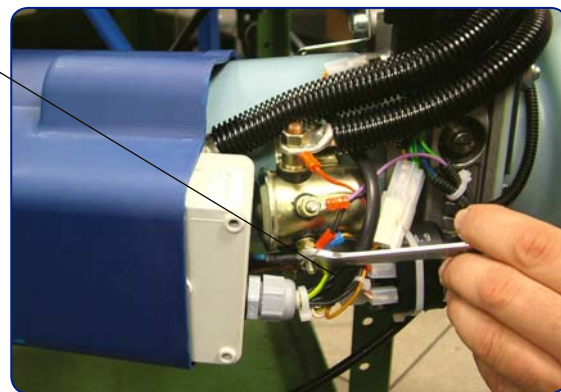
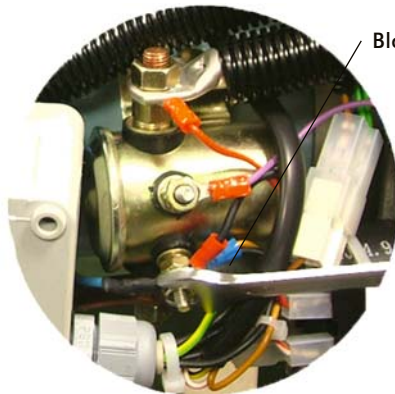

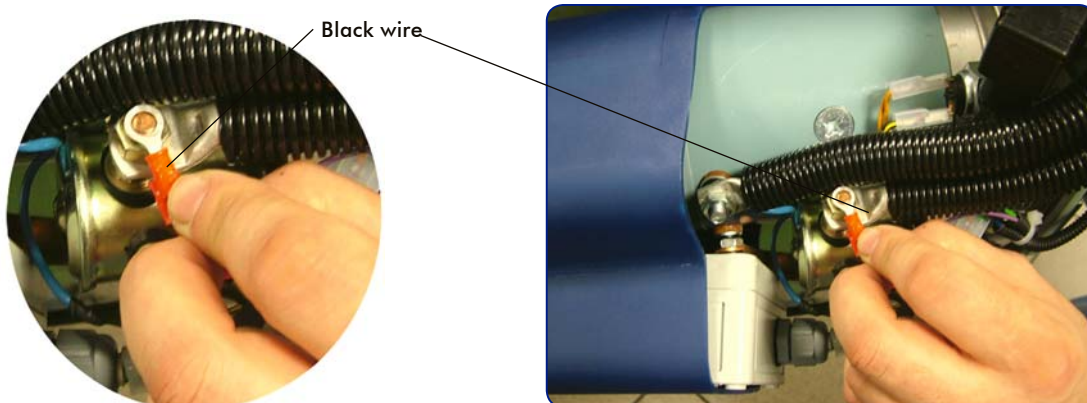

5.3.5 Turn on the new transmitter to be programmed

5.3.6 Turn on the receiver



5.3.7 Check that the transmitter's yellow Link led comes on.

5.3.8 Turn off the receiver



5.3.9 Disconnect the black number 6 wire from positive and connect to mass.

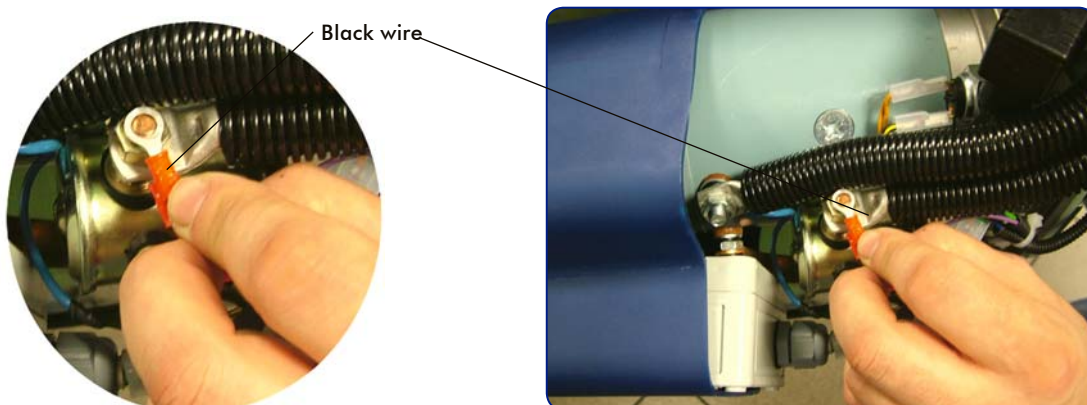

Data: Mercoledì 24 luglio 2013

Codice foglio: 997-101-50346 Rev: AB

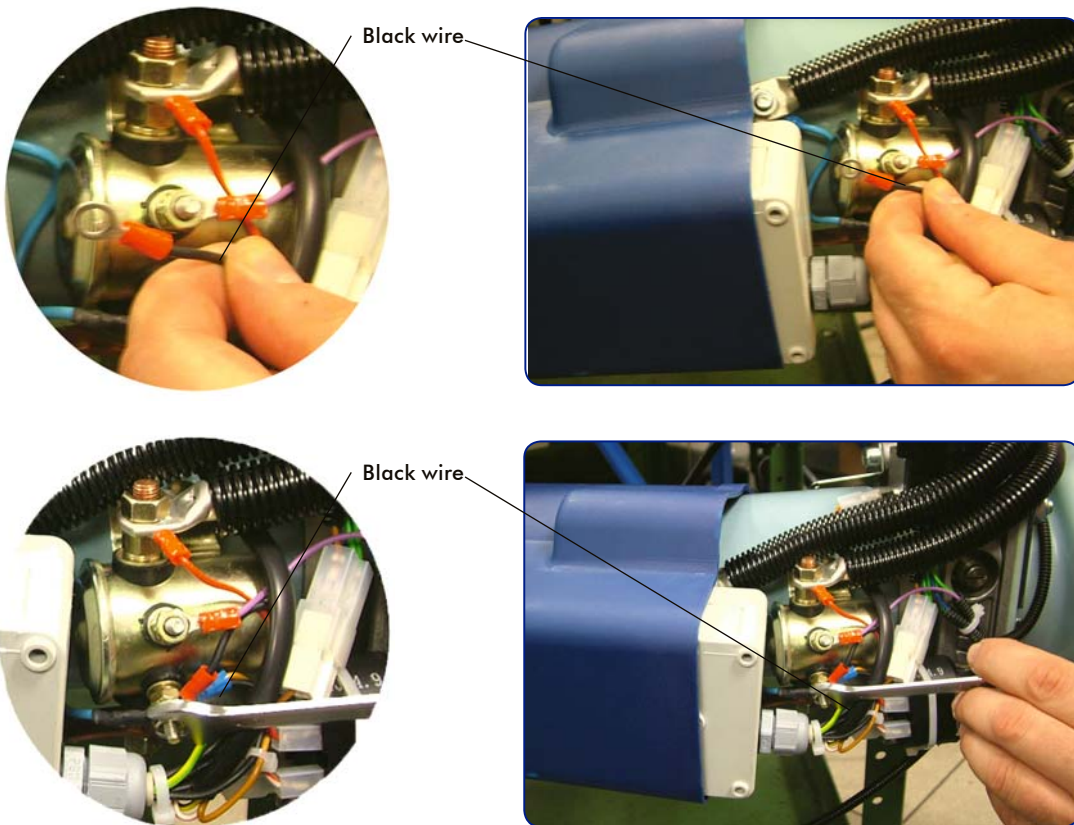

5.3.10 Put the guard back on.

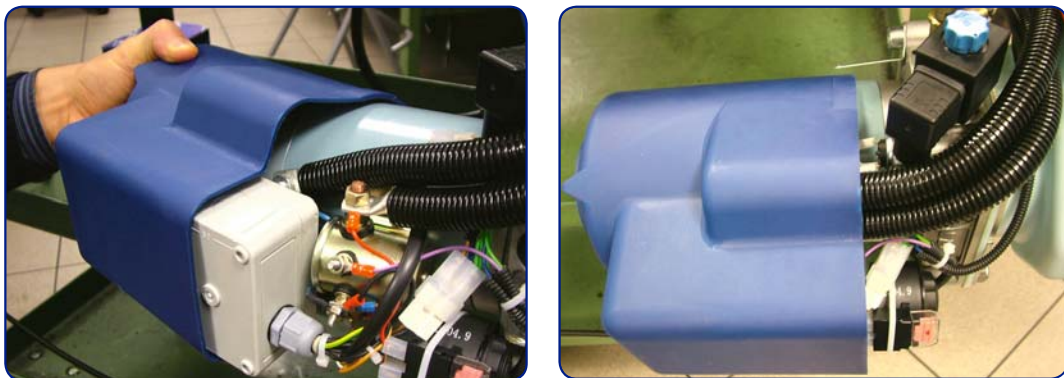

5.3.11 Turn receiver on again.



The system can memorise two different transmitters. Memorising a third transmitter cancels the first one memorised.

6. OPTIONAL CONFIGURATION FOR FITTING A DOUBLE CONTACTOR

The system can, on request, be fitted with a second contactor or an electronic disconnecter, to be connected as standard to the one in the control unit. Refer to the functional diagram for "OPTIONAL CONFIGURATION OF A DOUBLE EMERGENCY CONTACTOR" (page 18) and contact O.M.F.B. for further information and/or order codes.

7. SPARE PARTS

101-051-41356	TX
101-051-41365	RX
509-000-01215	HOLDER

8. STRUCTURAL AND FUNCTIONAL DIAGRAMS

8.1 STRUCTURAL WIRING DIAGRAM

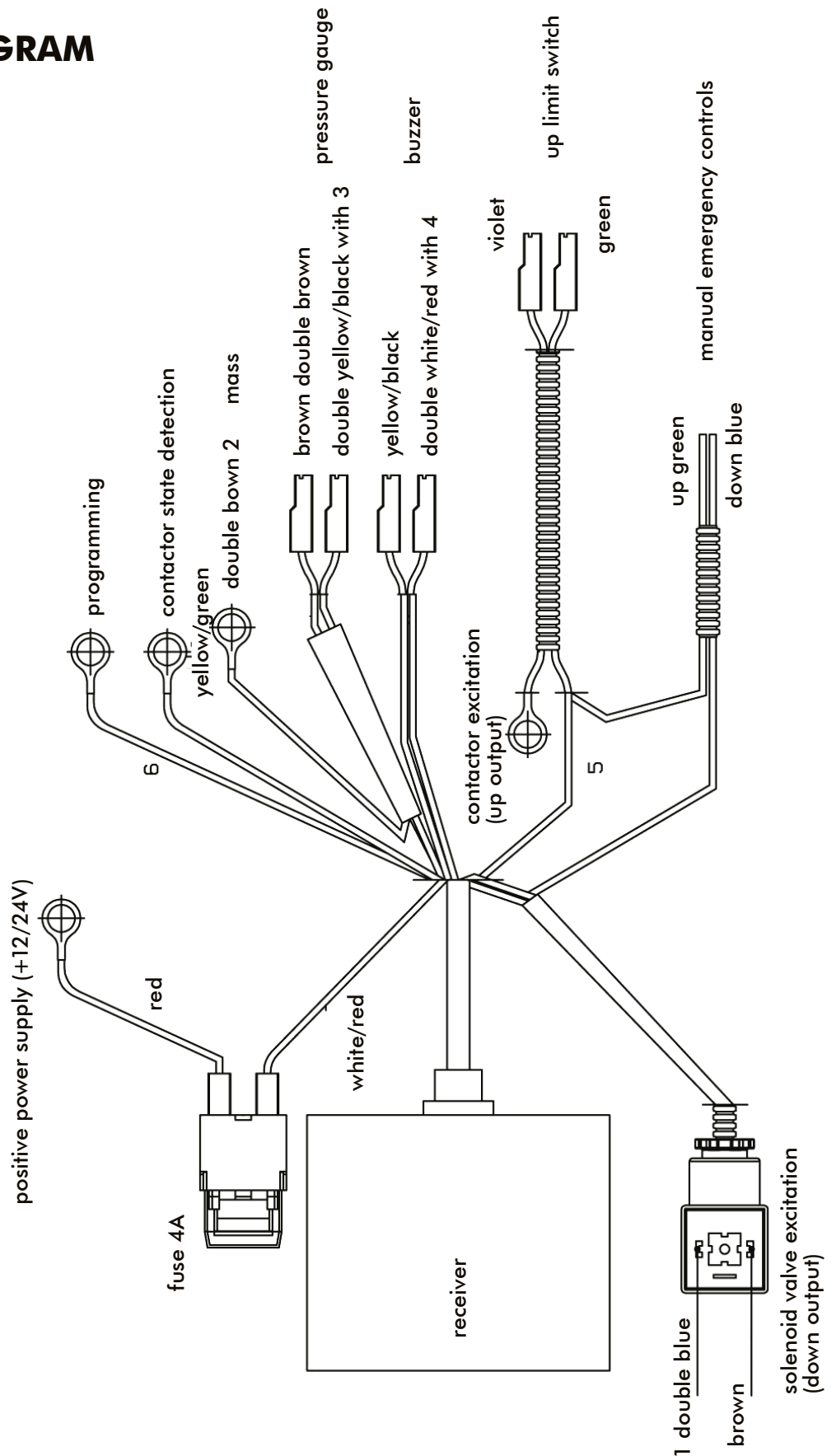

Data: Mercoledì 24 luglio 2013

Codice foglio: 997-101-50346 Rev: AB

8.2 COMPLETE FUNCTIONAL DIAGRAM

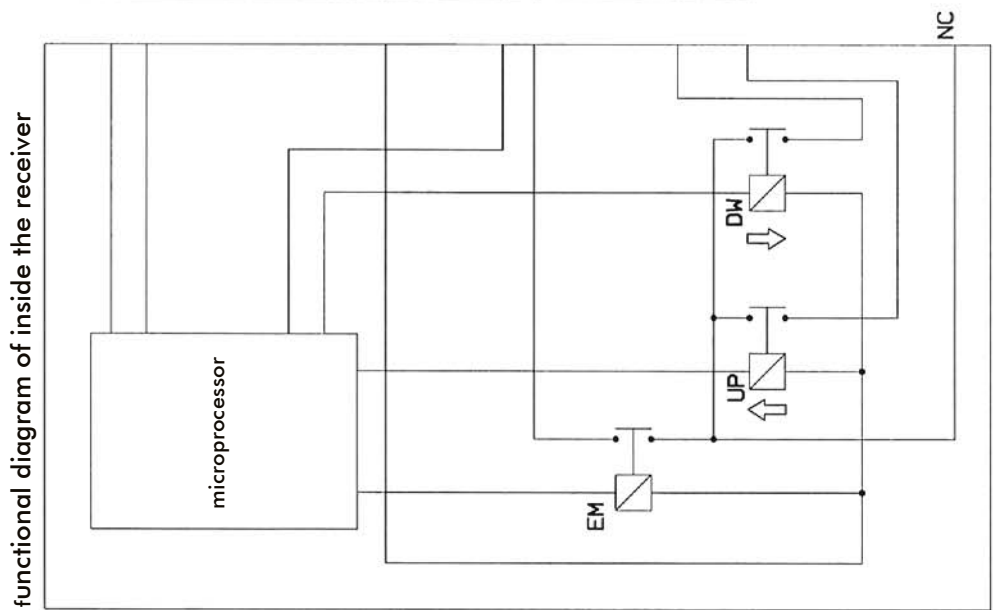
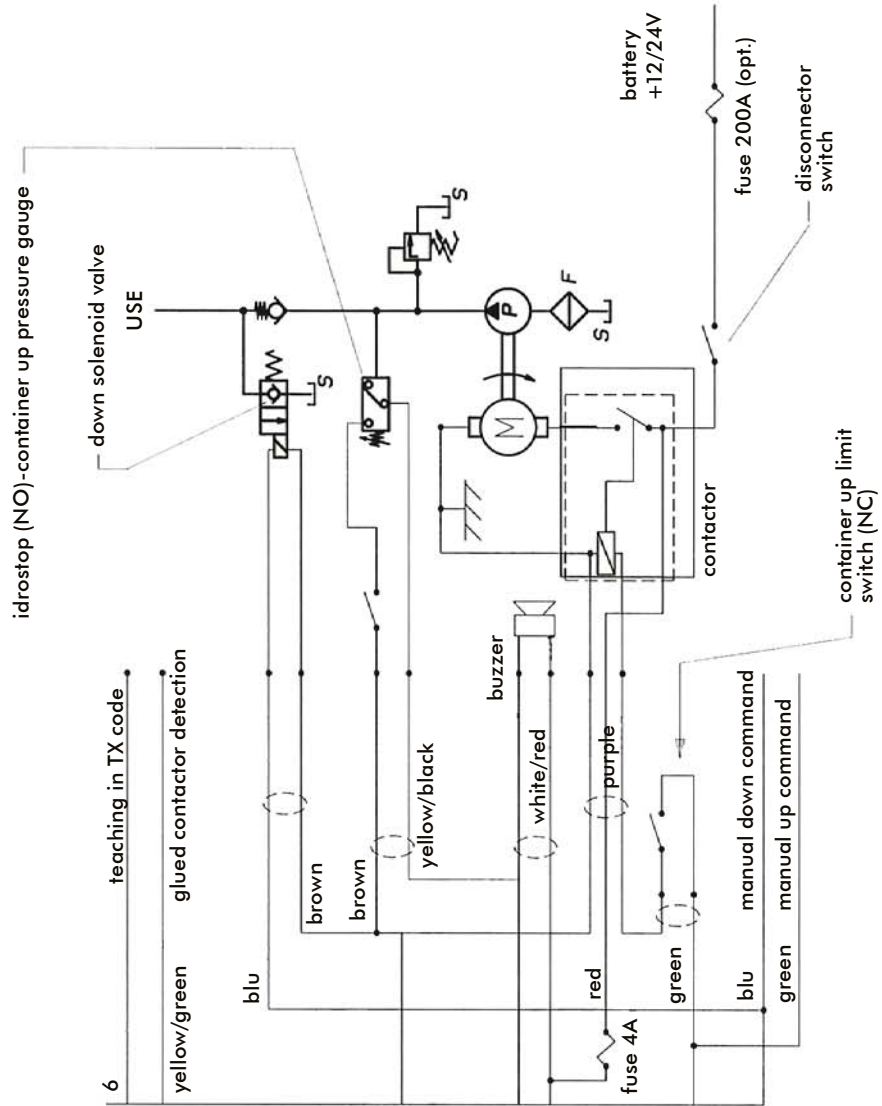

Data: Mercoledì 24 luglio 2013

Codice foglio: 997-101-50346 Rev: AB

8.3 CONFIGURATION DIAGRAM OF OPTIONAL DOUBLE EMERGENCY CONTACTOR (ref. paragraph 6 page 15)

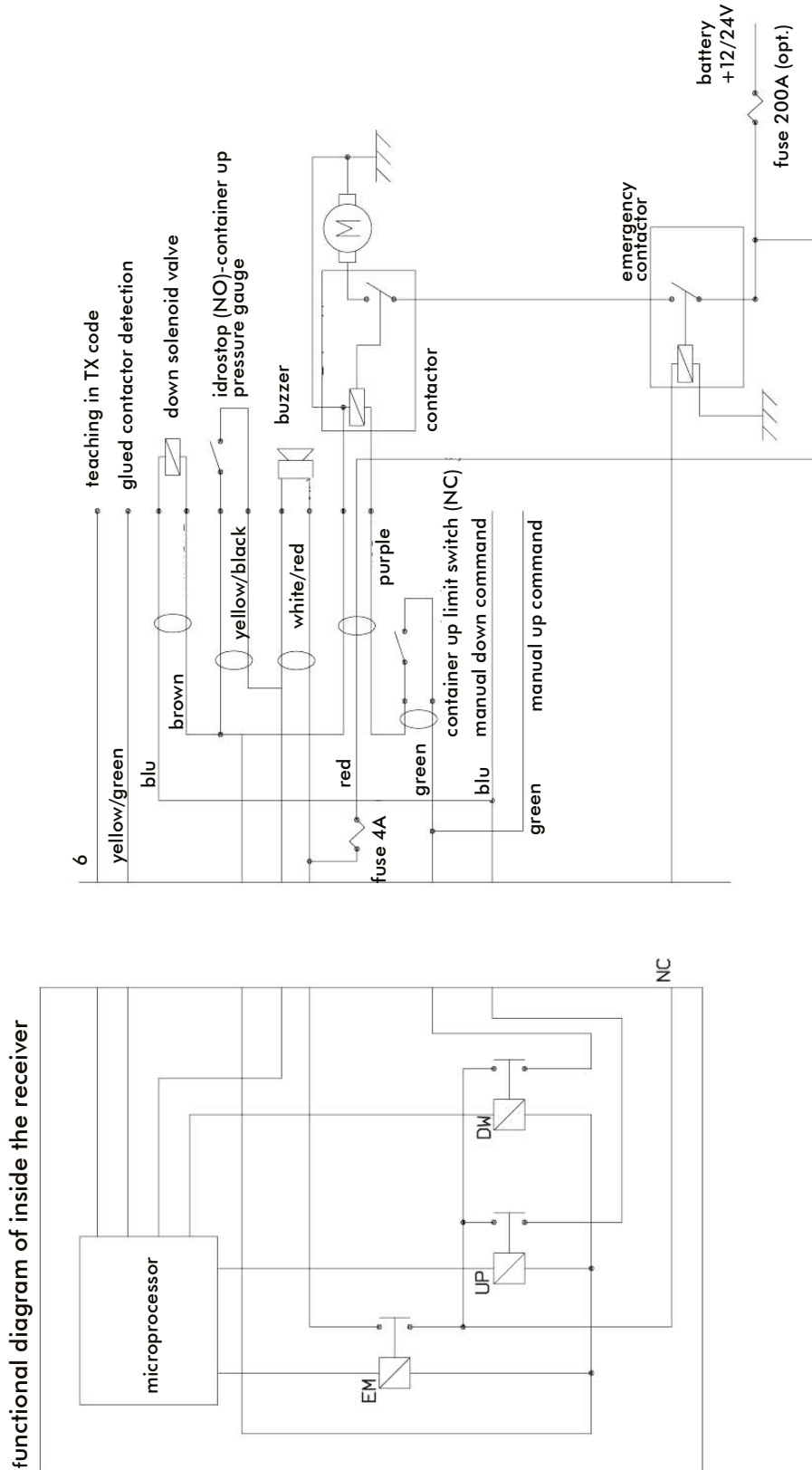

Data: Mercoledì 24 luglio 2013

Codice foglio: 997-101-50346 Rev: AB